

The Ray Allen Company Inc.

2525-8 Pioneer Avenue, Vista, CA 92081 USA Phone 760 599 4720 FAX 760 599 4383

www.rayallencompany.com

INSTALLATION INSTRUCTIONS FOR

T2-7A-TS, T2-10A-TS, T3-12A-TS TRIM SYSTEMS

ABOUT THE RAY ALLEN SERVO

NOTE: The T2-7A servo has .7" (17mm) travel, the T2-10A servo has 1" (26mm), and the T3-12A servo has 1.2" (31mm).

Ray Allen servos are constructed of a composite material that contains glass fibers added for strength and durability. Some of these glass fibers may appear as white smudges on the outside surface of the servo. This is caused by the injection molding process and while not very pretty, the fiber content makes for a very strong material.

Ray Allen servos operate on 12-14 volts DC. A lower voltage can be used, but will result in less power and slower speed. When activated, the servo will continue to run until the power is shut off or the output shaft reaches the end of its travel. Since the thrust is generated by means of a jackshaft (T2 models) or a jackscrew (T3 models), the output shaft will lock in any position when the power is shut off. The servos will not operate unless power is manually switched on by the pilot, no electronics are utilized in the servo. Voltage polarity determines the direction of travel.

INSTALLING THE SERVO

The following are a few general guidelines concerning servo installation. However, you should consult the manufacturer of your kit, or the designer of your aircraft, for any specific information about installing our electric trim.

For most aircraft designs, the trim servo will be installed inside the control surface to control a trim tab. It can also be used to adjust springs connected to a control surface. Ray Allen Servos can be mounted in any position, but they must be protected from water exposure. The mounting holes in the servo flange are 1/8" diameter. If you plan on securing the servo with 6-32 screws, you will have to carefully enlarge the flange holes. The servo should not be mounted with any larger diameter screws than 8-32.

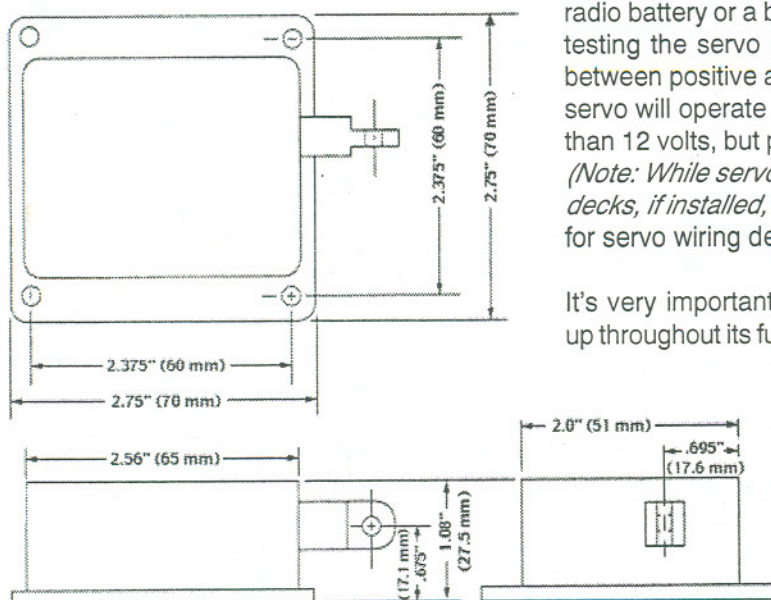

Although Ray Allen Servos use 12 volt motors, a 9 volt transistor radio battery or a battery pack from a cordless drill are very useful for testing the servo during the installation process. Switch the wires between positive and negative to reverse the direction of travel. The servo will operate slower and have less power than when using less than 12 volts, but performance will be adequate for testing purposes. *(Note: While servos may be tested at lower voltages, Ray Allen relay decks, if installed, require 12-14 volts to operate reliably).* See page 4 for servo wiring details.

It's very important that the servo does not bind up throughout its full length of travel. This includes making room for the leadscrew on the T3-12A servo when the output shaft is fully retracted.

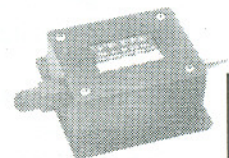

CAUTION! The output shaft is drilled for a 1/8" diameter clevis pin. **DO NOT** enlarge the 1/8" hole to accommodate a larger pin.

Warning: Installation and use of Ray Allen Company products is the responsibility of the aircraft designer and manufacturer. Use of Ray Allen products in any application which will exceed their capability can cause failure leading to injury or death.

ABOUT THE RC8-7 CLEVIS/PUSHROD KIT

Your trim system contains two clevises and a 7", 8-32 threaded, stainless steel pushrod. These clevises are drilled to accept a 1/8" clevis pin. The clevis pin should be a snug fit in the clevis to prevent slop in your trim system.

CAUTION!! DO NOT drill out the clevis to accept a larger diameter clevis pin! DO NOT grind off any of the clevis material to enable it to fit in a smaller space! These actions will result in weakening of the clevis and possible failure. DO NOT thread the pushrod in too far, the clevis is not tapped all the way through.

INSTALLING THE CLEVIS/PUSHROD KIT

The 7" long stainless steel pushrod can be shortened to suit your installation. If you intend to use a longer pushrod, do not use all-thread rod. Instead, make a pushrod from a thick wall aluminum tube, with threaded rod ends riveted into both ends.

CAUTION!! DO NOT make any sharp bends in the 8-32 threaded stainless steel pushrod! This will greatly reduce the pushrod's strength and possible failure could result.

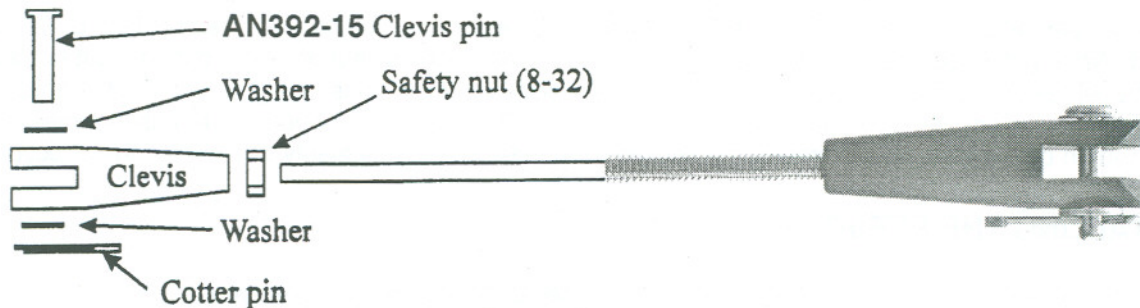

ABOUT THE RS2 ROCKER SWITCH

The RS2 rocker switch provided with your Ray Allen trim system is designed to electrically short the servo motor to ground (-) when released. This stops the output shaft without any coasting, allowing precise positioning when trimming your aircraft. The RS2 rocker switch is rated at 1 amp.

NOTE: If you want to use this rocker switch along with a stick grip mounted switch, or any other switch, to simultaneously control a servo, you must use a different wiring diagram (available through our web site at www.rayallencompany.com).

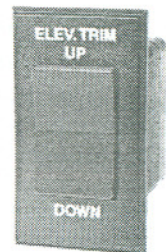

INSTALLING THE ROCKER SWITCH

Use the dimensions shown at right to cut the mounting hole for the rocker switch. The rocker switch can be mounted in any position using the two 2-56 countersunk screws, washers and nuts provided. See Figure 1 on page 4 for rocker switch wiring instructions.

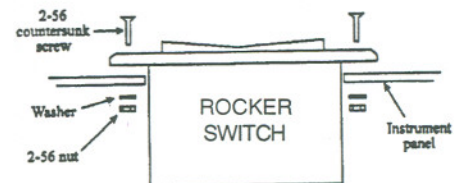

If you intend to use a different switch to actuate the servo, refer to Figure 2 or Figure 3 on page 4 for wiring methods. You must use either a DPDT switch or two SPDT pushbutton switches. Wires as small as 28 gage may be used. Ray Allen has color coded 5 wire installation cable available for this purpose. Wiring connectors are not included. Use any type desired or simply solder all connections and insulate with heat shrinkable sleeving. A 1 amp fuse or circuit breaker is recommended.

A self-adhesive label is available at no charge. Just send us a self addressed, stamped envelope requesting what type label you need. See our web site at www.rayallencompany.com for label types. Make sure the label is not rubbing on the sides of the rocker.

PANEL CUT-OUT (NOTE: DRAWING NOT TO SCALE)

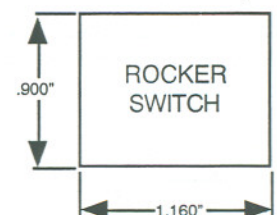

ABOUT THE POSITION INDICATORS

The standard position indicator supplied with your Ray Allen trim system is the RP3 LED type indicator. It uses ten LED lights to show you the position of the servo output shaft. Although we designed it with some of the brightest LED lights available, direct sunlight will still affect your ability to see the active light. Because of this, the position indicator should be mounted somewhere in the shade on your panel, preferably just under the sun shield.

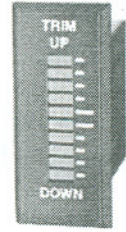

For night flight, the bright LEDs can be dimmed. This dimming function is either ON or OFF and is not designed to be variable. The dimming function is optional and does not have to be used (just cut off the white wire).

CAUTION!! DO NOT connect 12V+ to the orange wire and DO NOT use the LED type indicator with an alternator, rectifier or a battery charger without a battery in line. We suggest wiring the indicator into the avionics side of your aircraft's electrical system. DO NOT connect the orange wire to 12V+.

INSTALLING THE RP3 LED TYPE POSITION INDICATOR

Use the dimensions shown at right to cut the mounting hole for the indicator. The LED indicator can be mounted in any orientation with the two 2-56 countersunk screws, nuts, and washers provided. See Figure 4 on page 4 for wiring instructions.

Wires as small as 28 gage may be used. Connectors are not supplied. Use any type desired, or simply solder all connections and insulate with heat shrinkable sleeving. A separate 1 amp fuse or circuit breaker is recommended.

A self-adhesive label is available at no charge. Just send us a self addressed, stamped envelope requesting what type label you need.

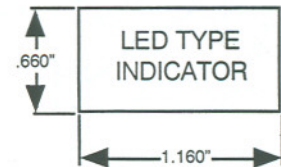
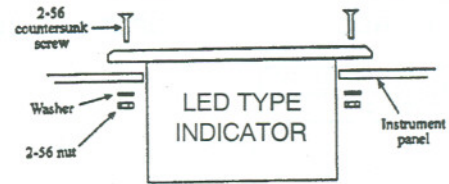

PANEL CUT-OUT
RP3 LED INDICATOR
NOTE: DRAWING NOT TO SCALE.

INSTALLING THE RP2 NEEDLE TYPE POSITION INDICATOR

Use the dimensions shown below to cut the mounting hole for the optional RP2 needle type indicator. The indicator is mounted with the "C" shaped clamp provided. See Figure 5 for wiring instructions on page 4.



Because of the delicate balance on the registering needle, the indicator must be mounted with its "TOP" label towards the...uh...top. The indicator's needle balance is set at the factory and should not require any further adjustments. However, there is a small adjustment capability where the needle stops at the far end of the display. To adjust where the needle stops, carefully insert a small #1 screwdriver in the hole in the back of the indicator and twist to put the needle where you desire. Make sure the servo is in the fully extended position when adjustments are made.

If, after wiring your indicator the needle moves in the opposite way you desire, DO NOT flip the needle indicator upside down: simply reverse the orange and blue wires that connect it to the servo. If the needle needs adjusting after the orange and blue wires are reversed, do it with servo in the fully retracted position.

CAUTION!! DO NOT connect the orange wire of the RP2 needle type indicator to 12V+. This damages an internal diode.

A self-adhesive label is available at no charge. Just send us a self addressed, stamped envelope requesting what type label you need.

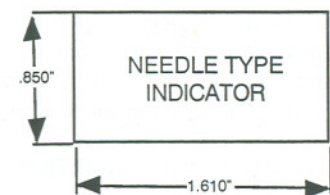
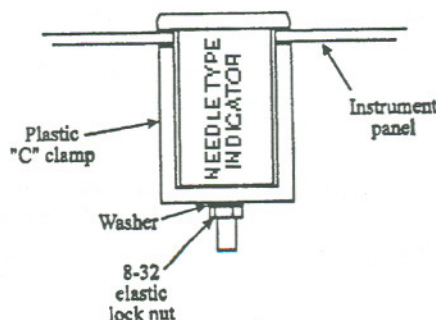

PANEL CUT-OUT
RP2 NEEDLE INDICATOR
NOTE: DRAWING NOT TO SCALE.

FIGURE 1 RAY ALLEN ROCKER SWITCH

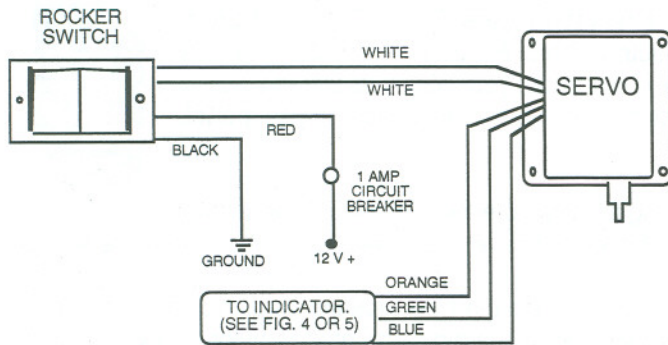

FIGURE 2 TWO SPDT PUSHBUTTON SWITCHES

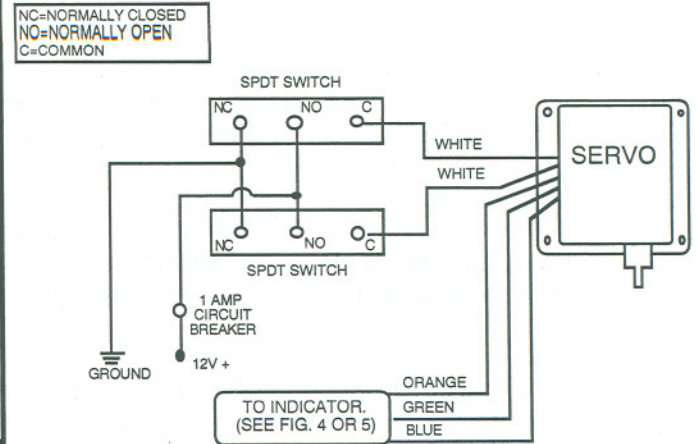

FIGURE 3 DPDT SWITCH

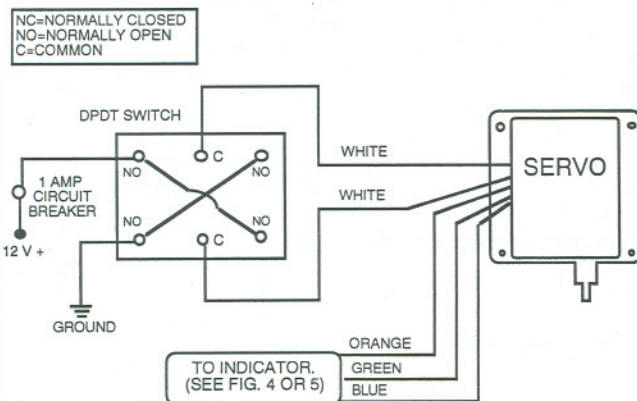

FIGURE 4 LED TYPE POSITION INDICATOR

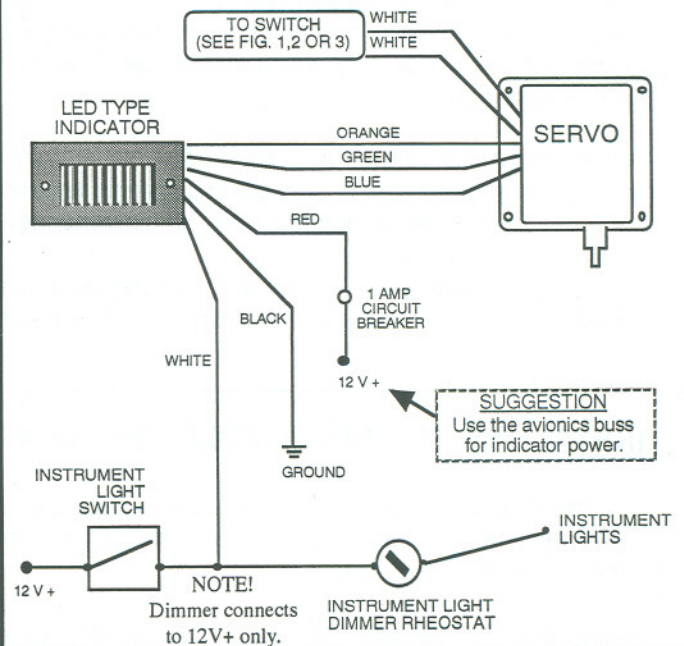
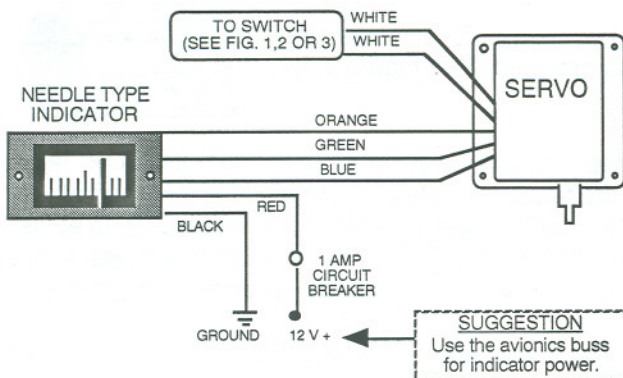

FIGURE 5 NEEDLE TYPE POSITION INDICATOR



For more information on other products the Ray Allen Company manufactures, download our brochure at:

www.rayallencompany.com

CAUTION!

Ray Allen Company, Inc. does not recommend that servos be installed in an aircraft to operate any apparatus or control surface that, if failure were to occur, could result in mechanical damage or control malfunction. When a servo is installed in an aircraft, all weight and balance, including that of the control surface, will be affected. Servos should not be installed unless you have full knowledge of the effects of this change on weight and balance or flight characteristics.

WARRANTY INFORMATION

All Ray Allen Company, Inc. products are warranted for one year from date of purchase. If you should have problems within that period, return the product to Ray Allen. We will repair it at no cost to you if it is determined that the failure occurred through normal use and not due to abusive treatment or faulty electrical wiring.