



## Altitude Hold Autopilot Mod 76

**TITLE :** Installation of Altitude Hold Auto-pilot  
(Trio, TruTrak, Dynon).  
**APPLICABILITY :** All Europa variants except Glider  
**Mod Type :** During build or Retro-fit

### 1. Introduction

Owners may wish to install altitude hold capability to a new or existing auto-pilot installation. The basic single axis (roll) wing levelling auto-pilot is documented as Mod 75. This modification provides the connection to the CS10 torque tube (located below the wing spars) to allow altitude hold. General instructions are given below. A separate appendix is provided for each type highlighting issues specific to that type. Make sure you read the appropriate appendix with the main document. The location of the servo conflicts with the air brake fittings for the glider wing. The location of the "D" type electrical connector on the current model of the TruTrack servo makes this autopilot unsuitable for use in monowheel aircraft." Before commencing work read the entire modification instructions and obtain a current copy of any applicable local regulations.

UK builders will require the LAA Inspection Checks LAA/IC-APP (available from the LAA web site). If you wish to deviate from these instructions including use of a different controller or servo to those detailed, you must consult LAA Engineering.

### 2. Parts List

Qty	Part No.	Description	Source
1	CS10/2	Revised torque tube	Mod 76 Kit.
1	F41	Push rod cover	Mod 76 Kit
1	PLY14	3mm ply mount board	Mod 76 Kit
4	MS21047-3	Captive nut	Mod 76 Kit.
8	TAPK 36 BS	Pop Rivets	Mod 76 Kit
4	MS35207-266	Machine screw, servo to board	Mod 76 Kit
4	AN960-10L	washer servo to board	Mod 76 Kit.
2	AN3-7A	Bolt Rod end to horn	Mod 76 Kit
2	MS21042-3	Stiff nut	Mod 76 Kit
4	EUR 069	Safety Washers	Mod 76 Kit
4	AN3-3A	Bolt, servo to mount (TruTrak)	Mod 76 kit
4	AN960-10	Washer servo mount (TruTrak)	Mod 76 Kit
<b>Other Parts</b>			
	GPS unit	With NMEA output	Better than 1 output per second
	Controller/Servo	See appendix	Autopilot supplier
	Mounting kit	See appendix	Autopilot supplier
	Composite	92125 Bid and Ampeg 20	Stock
		Araldite 420+ Flox	Stock
		Pitot & Static connectors	As required

See the manufacturer's documentation for recommended GPS units and connection details.

### List of related Drawings / Photo's

Drawing No.	Title / Description	Issue
Mod 76 /1A & B	TruTrak & Dynon general view and details	1
Mod 76 /2A& B	Trio general view and details	1
Picture 1	General view (TruTrak)	1
Picture 2	Servo and push rod (TruTrak)	1
Picture 3	Seat back access hole	
Picture 4 & 5	Push rod cover incorporated in seat base	
	Manufacturer's installation instructions	



## Altitude Hold Autopilot Mod 76

### 3 Action

3.1 **Servo Installation Overview.** The servo is installed in the port (pilot) inboard thigh support locker. The servo control crank is linked to a new horn on the revised CS10 torque tube (that runs behind the passenger seat) via a push rod. For general layout see picture 1 and drawings. The push rod is protected with a composite cover.

3.2 **Access Opening.** The access opening is made as per the drawing in the appendix. Position the access hole relative to actual position of the inboard seat rib. Ensure the servo will fit in the position indicated. Remove about 5-10mm (1/4" – 3/8") of the foam core between the skins around the access holes and fill with epoxy/flox to reinforce the edges. A covers MUST be made and fitted to this access hole. A cover must also be fitted over the front opening of the thigh support to prevent foreign objects from entering.

3.3 **Thigh support Hole.** The push rod passes through a hole in the thigh support. Cut the hole in the sloping seat face to allow the actuator rod to pass through. Remove about 5-10mm (1/4" – 3/8") of the foam core between the skins around the hole and fill with epoxy/flox to reinforce the edges. The holes must be made large enough to allow for the movement of the push-rod when full tailplane movement in both directions is applied, with additional 3-6mm (1/8" – 1/4") clearance around.

3.4 **Seat Back.** The push rod passes through a hole in the seat back. Cut two 38mm diameter holes, 23mm apart, as indicated on the drawing and picture 3. File off the pointed area between the cuts. Seal the edges with a coat of epoxy resin. The holes may be smaller but this size gives reasonable access to the attachment bolt.

3.5 **Servo support board.** The servo (and bracket if TruTrak or Dynon) is mounted on a 3mm ply board (PLY14), just above the floor, so that all loads imposed by the servo are taken by the thigh support ribs. The servo is bolted to the mount to allow removal for servicing. Due to building tolerances you must cut the board to the dimensions of YOUR aircraft. Cut the board to size and trial fit. Apply one layer of BID and epoxy to each side. When cured cut the lightening/clearance holes and seal the edges with epoxy. Make sure that the position of the servo is such that the push rod will be parallel to and 89mm (3.5") from the port pitch push rod centre line. Drill the holes to mount the servo, install the MS21047-3 captive nuts using the TAPK 36 BS rivets. Mount the servo and cut the MS35207-10R14 machine screws to length (leaving 1½ threads through the captive nut). Remove the servo and install the board 8mm (5/16") above the aircraft floor. Scuff sand the area of the joint, flox the edges between the board and the ribs and make a bracket with two plies of BID overlapping 18mm (¾") onto the board and ribs. Use grease to prevent epoxy entering the captive nuts. When cured remount the servo.

3.6 **CS10 Removal.** Access in this area is difficult and you may require ratchet spanners to facilitate this work.

- a) Remove the Quick connect bellcrank (CS15) and push rod from both sides of the aircraft to allow access. Remove the aileron cross link push rod to allow removal of the fuel tank spacers.
- b) Remove the fuel tank spacers.
- c) Carefully remove the bolts connecting the port and starboard pitch push rods (CS6) and the pitch push rod (CS17) to the CS10. Make careful note of the position of all washers (for washer details check Europa Build manual Pages 15.3 and 18.7).
- d) Remove the two AN4-10A bolts holding CS10 to the bearings in the CS09 brackets.
- e) Remove the CS9 bracket on the port side.
- e) The CS10 can now be removed by lifting it and moving it to port. It will then clear the CS08 cranks.

3.7 **CS10/2 Installation.** The existing CS10 is replaced by a CS10/2 with the additional horn needed to attach the auto-pilot's push rod. Assembly of the washer between the rod end



## Altitude Hold Autopilot Mod 76

bearings and the horns is extremely difficult in situ. To avoid this scuff sand the washers and horn and glue these washer in place with Araldite 420 on all four horns. Reassembly is the reverse of removal.

3.8 **Push Rod.** The servo to CS10/2 push rod must be cut to length and assembled with the rod-end bearings. The method varies slightly by type (see appendix 1, 2 and 3). **The rod end bearings must be locked to the control rod (with check nuts) and a safety washer fitted.**

3.9 **Push Rod Cover.** The push rod cover (F41) supplied must be installed to protect the push rod. The cover must not be able to move (and potentially touch the push rod) under any conditions. As the treatment of the seat base area is not specified in the build manual the builder is responsible for ensuring this condition is met. If, as many builders have done, you have shaped foam pieces filling this area the cover may be cut into this foam. Apply epoxy and micro to glue the cover to the foam and add a single layer of BID to the base to ensure the cover is held firmly in place. See pictures 4 & 5. Alternately the cover can be bolted. It is not advisable to glue the cover in place as this would hamper future removal of the push rod.

3.10 **Controller Instrument Installation.** The instrument may replace the attitude indicator or be installed separately in a new position on the panel. Check that your intended installation meets the requirements of LAA/IC-APP. (see Appendix 1 or 2)

3.11 **Disconnect switch.** A disconnect switch is required to be fitted which is easily accessible from either seat. This may be incorporated in joystick-mounted switches or on the panel. Check that you meet the requirements of LAA/IC-AP.

3.12 **Wiring.** See the wiring diagram in the manufacturer's documentation. All wiring must be properly insulated and supported. (Note limitation for Trutrak, see Appendix 1)

### 4 Weight and Balance

	Weight (lb/kg)	CG (in/mm)	Moment
Existing A/C			
+/- Weight Change	+2 lb	52 in	104 lb.in
Post Mod A/C			

Amend the aircraft weight and balance schedule accordingly.

### 5 Flight Test and Special Instructions

5.1 The following instructions are designed to ensure compliance with the UK LAA requirements set out in Inspection Checklist (LAA/IC-APP). Different or additional requirements may be applied by other authorities.

5.2 Specific ground and flight test instructions are given in the manufacture's documentation. These MUST be carried out fully. In particular:-

- 1) Make sure the servo is operating in the correct sense.
- 2) Make sure the servo can be overridden manually.
- 3) Make sure that there is no possibility for the servo crank to reach an angle relative to the push-rod to cause over-centre geometric lock or otherwise jam.
- 4) Make sure that, should the servo arm become detached, the push-rod or servo arm cannot cause an elevator control jam.

5.3 LAA inspector to check the completed work, sign off the checklist (LAA/IC-APP), raise a log-book entry for Mod 76, update weight schedule and issue Permit Maintenance Release.



## Altitude Hold Autopilot Mod 76

5.4 Return to LAA Engineering the completed inspection checklist with request for flight test authorisation. Note: Before receipt of flight test authorisation – PFRC (Permit Flight Release Certificate) the modified aircraft may only be flown if the push-rod between the servo and aircraft control system is removed. Disconnection alone is not acceptable.

5.5 With valid PFRC, conduct flight test according to flight test schedule LAA/FT-APP.

5.6 Return to LAA Engineering completed flight test schedule.

Notification of final approval will be sent to the applicant. Until this is received, the aircraft may only be flown if the push-rod between the servo and aircraft control system is removed.



Picture 1 Example TruTrak installation. Viewed through access holes in thigh support.



Picture 2 Example TruTrak installation.

Picture 3 Seat back access hole.



## Altitude Hold Autopilot Mod 76



Picture 4 Push rod cover incorporated in seat base



Picture 5 cover bonded to seat base

### Appendix 1 TruTrak

The TruTrak servo is a slow speed digital stepper motor. Unlike the analogue servos the centre (Null) is not fixed and can be anywhere.

The location of the "D" type electrical connector makes this autopilot unsuitable for use in monowheel aircraft.

See also three drawings at the end of this document.

#### 2. Parts List

Qty	Part No.	Description	Source
1	Controller	a) ADI Pilot II b) Digitrak (G,VS,VSG) c) EFIS	TruTrak Flight Systems 1500 S Old Missouri Road Springdale Arizona, AR 72764-1157, USA
1	DSB B	Digital Servo	
1	EUR-R	Mounting kit	
1	Push Rod	22" push rod	

#### 3. Additional/Alternative Actions. Read with main sections

3.1 **Servo** Check that the servo arm retaining screw has been replaced (see service bulletin 21/01/2009). If not remove the servo arm retaining screw and re-install it with Loctite 243 or a suitable equivalent. Install the screw retainer (see Service Bulletin 06/08/2010). If this screw is ever removed in service, it must be re-installed using Loctite 243 or a suitable equivalent and the screw retainer replaced. The servo needs to be bolted to the TruTrak bracket with the AN3-3A bolts and AN960-10 washers provided.

3.5 **Servo support board.** The arm of the TruTrak servo extends below the mounting bracket in this configuration. Using scrap ply, Make up two mounts 9mm high on which the servo mount will rest. Check that the push rod and arm have 3mm clearance all round. A hole must be cut into the centre tunnel to make the electrical connection. Seal the exposed edges of the hole with epoxy



## Altitude Hold Autopilot Mod 76

3.8 **Push Rod.** The push rod must be cut to length and assembled with the rod-end bearings. A new thread will need to be cut in the control rod with a 10 x 32 UNF tap. The rod-end bearings can then be assembled. ). **The rod end bearings must be locked to the control rod** (with AN345-10 nuts) **and a safety washer fitted.**

3.10 **Controller Instrument Installation.** The ADI Pilot II replaces the attitude indicator. The Digitrak will require a new position on the panel. Check that your intended installation meets the requirements of LAA/IC-APAH.

3.12 **Wiring.** The supplied "D" type connector shell will extend through a hole into the centre tunnel (see picture 1). This may make the use of the TruTrak system unsuitable for monowheel aircraft.

### Appendix 2 Trio

See also three drawings at the end of this document.

#### 2. Parts List

Qty	Part No.	Description	Source
1	Controller	a) Pro Pilot b)EZ Pilot + Alt HOLD	Trio Avionics 1820 Joe Crosson Drive, El Cajon California 92020, USA
1	Gold Servo	Servo	
1		Mounting kit & Arm	
1		22" push rod	

The Trio "Gold Servo" can be supplied with a mounting base identical to the Navaid S2 servo "A" or with a Trio base which is slightly larger "B".

#### 3. Additional/Alternative Actions. Read with main sections.

3.1 **Servo Installation Overview.** This analogue servo has a fixed centre (Null) and the actuator arm may need to be repositioned. The arm retaining screws must be installed with Loctite 243 or a suitable equivalent.

3.8 **Push Rod.** The control rod must be cut to length and the tapped insert riveted in place. The rod-end bearings can then be assembled. **The rod end bearings must be locked to the control rod** (with AN345-10 nuts) **and a safety washer fitted.**

3.10 **Controller Instrument Installation.** The EZ Pilot/Pro Pilot may replace the turn coordinator or be installed as an additional instrument. Check that your intended installation meets the requirements of LAA/IC-APAH.



## Altitude Hold Autopilot Mod 76

### Appendix 3 Dynon

This Modification applies to an altitude hold servo motor driven by one of the following Dynon controllers:-

- a) Skyview EFIS
- b) D10/D100 series EFIS
- c) The above with the AP74 Dedicated Autopilot interface

The Dynon servo is dimensionally identical to the TruTrak servo. The servo is a slow speed digital stepper motor but is NOT electrically compatible with the TruTrak. The centre (Null) is not fixed and can be anywhere. This servo is suitable for use in a Monowheel aircraft as the electrical connection can be accommodated. The Dynon mounting kit DOES NOT provide a drive rod of sufficient length or supply a mounting bracket.

See "Dynon Servo Mounting Instructions – Generic Push-Pull Kit" and the drawings at the end of this modification document.

#### 3. Parts List

Qty	Part No.	Description	Source
1	Controller	See list above	Dynon Avionics 19825 141 <sup>st</sup> PL NE Woodinville WA 98072, USA
1	SV32	Servo	
1	Mounting kit	Generic (push-Pull)	

#### 3. Additional/Alternative Actions. Read with main sections.

3.4 **Servo Installation** The servo needs to be bolted to a bracket with AN3-3A bolts and AN960-10 washers provided. The TruTrak bracket can be used or a similar bracket made (see Pictures 1 & 2).

3.6 **Push Rod.** A control rod (500mm (19") in length) must be obtained and cut to length and threaded 1/4" x 28 UNF tap. See the Dynon notes include with the mounting kit for suggested materials. The rod-end bearings can then be assembled. **The lock nuts and safety washers must be fitted.**

3.7 **Controller Instrument Installation.** Use of the basic EFIS will require no additional panel space. The AP74 will require a new position on the panel. Check that your intended installation meets the requirements of LAA/IC-APP.



Throttle

Centre Tunnel

TruTrak Connector intrudes into centre tunnel

Fuel hose

Access hole

Thigh support hole

Servo push rod  
Rod length is centre to centre length minus 40mm

Ply rib

Ply rib

# TruTrak & Dynon

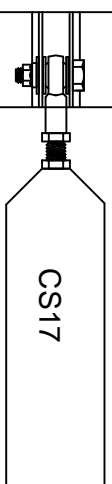

CS10

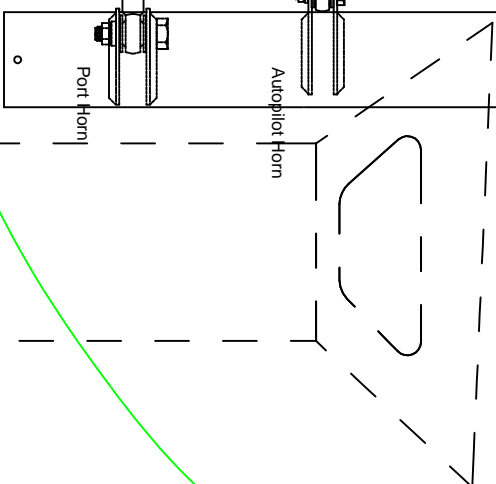

Port Horn

Autopilot Horn

Drawn By I. F. Rickard  
Date 05/04/2011

Title  
**Altitude Hold Autopilot - Mod 76**  
TruTrak & Dynon plan

Checked by  
Date

PFA A/C Type  
Europa XS  
Scale 1:3.5

Serial No  
247-13714  
A/C Regn G-IANI

Drawing No  
Mod 76/1A

Drawing Sheet 1 of 4

Rev  
2



# TruTrak & Dynon

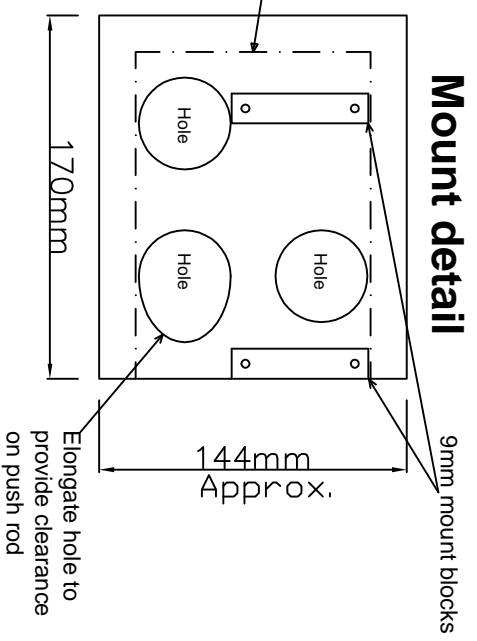
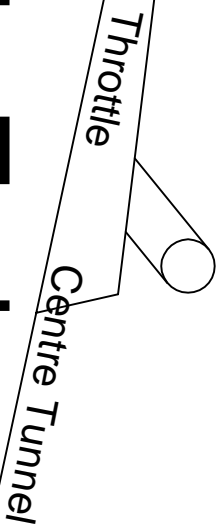

## Seat back access hole detail

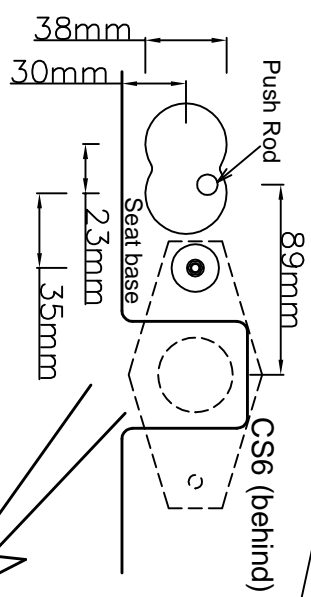

## Head rest

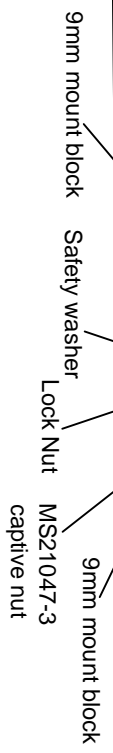
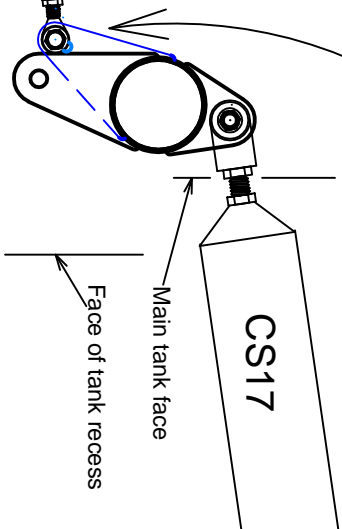

Drawn By I. F. Rickard	Title		
Date 29/12/2010	Altitude Hold Autopilot - Mod 76		
Checked by	TruTrak & Dynon elevation		
Date	PFA A/C Type Europa XS	Serial No 247-13714	Drawing No Mod 76/1B
Scale 1:3.5	A/C Regn G-IANI	Drawing Sheet 2 of 4	
			Rev 2



Centre Tunnel

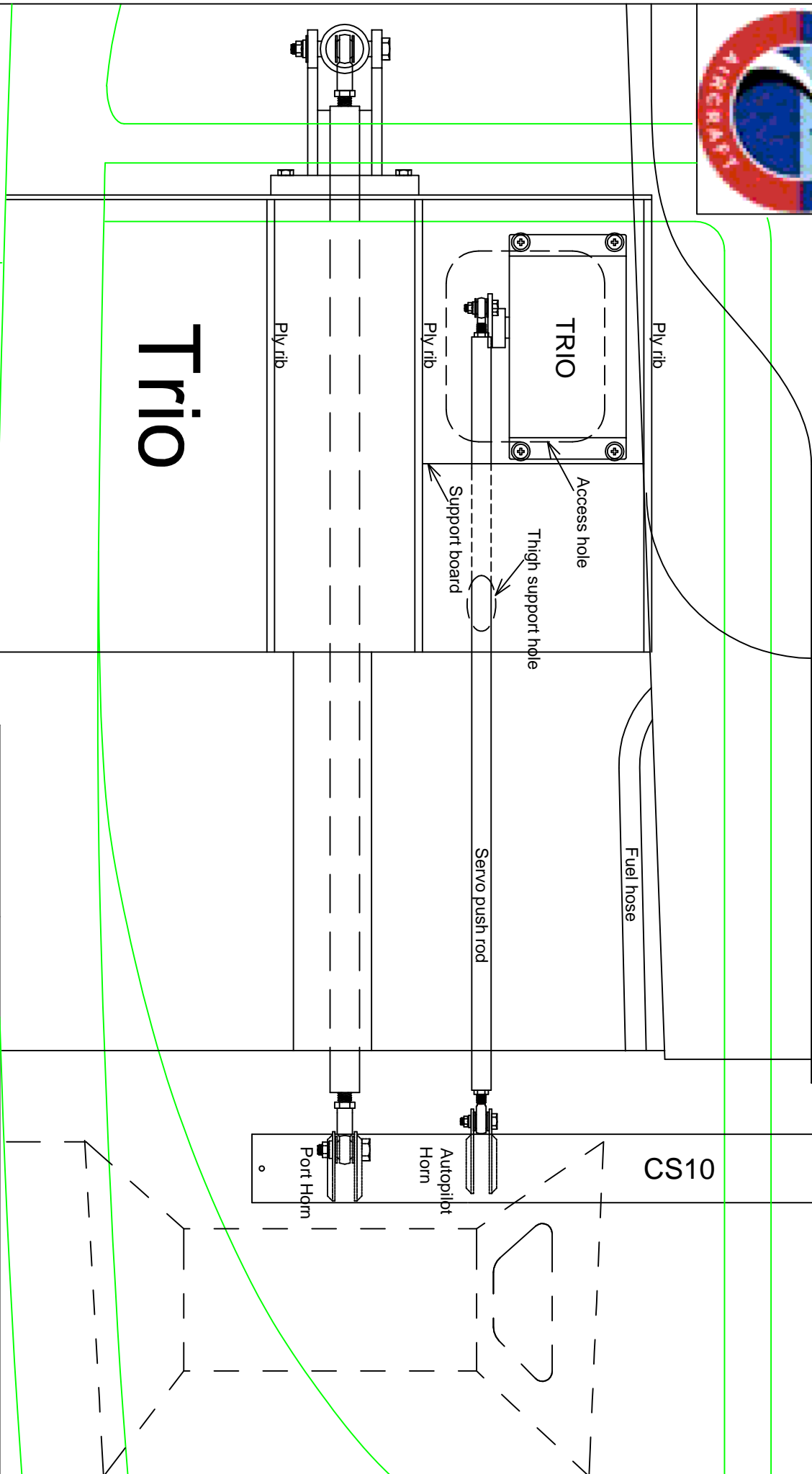

Drawn By I. F. Rickard  
Date 29/11/2009

Checked by  
Date

Title  
**Altitude Hold Autopilot - Mod 76**  
Trio actuator arm plan

LAA A/C Type  
Europa XS  
Scale 1:3.5

Serial No  
247-13714  
A/C Regn G-IANI

Drawing No  
Mod 76/2A

Drawing Sheet 3 of 4  
Rev 1



Throttle

Centre Tunnel

**Trio**

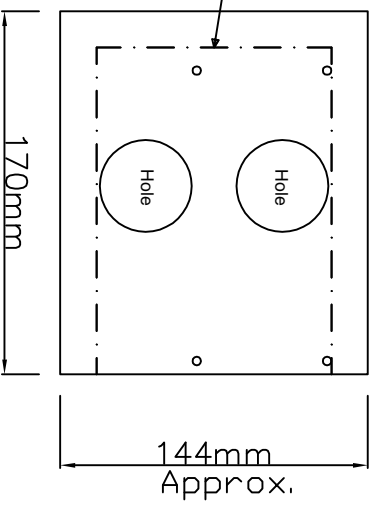
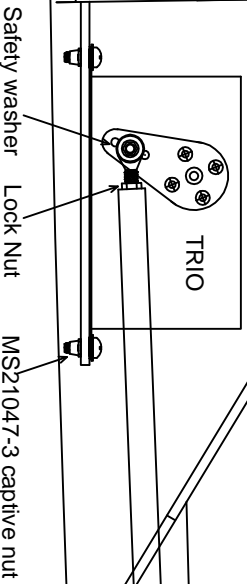

**Mount detail**

**Seat back access hole detail**

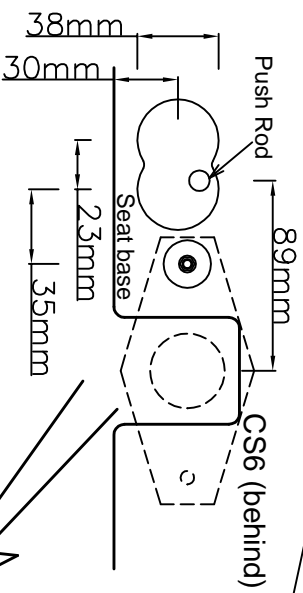

Head rest

New horn on CS10

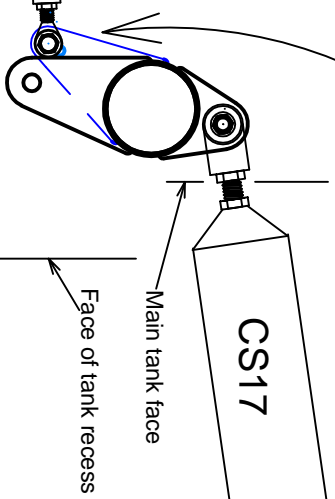

Drawn By I. F. Rickard Date 29/11/2009		Title <b>Altitude Hold Autopilot - Mod 76</b> Trio actuator arm elevation	
Checked by Date	PFA A/C Type Europa XS	Serial No 247-13714	Drawing No Mod 76/2B
Scale 1:3.5	A/C Regn G-IANI	Drawing Sheet 4 of 4	
		Rev 1	