

BRP-Powertrain

MAINTENANCE MANUAL

15) Propeller gearbox

General note **NOTES:** The following “free rotation check” and “friction torque check” are necessary only on engines with the overload clutch as optional extra.

Engine without the overload clutch Engines without the overload clutch (slipper clutch) have no free rotation. For this reason the friction torque method cannot be applied on engines without overload clutch.

15.1) Checking the friction torque in free rotation

General note See Fig. 31.



WARNING Risk of electric shock!
Switch off ignition and remove key! Disconnect negative terminal of aircraft battery.

Test procedure The following steps are necessary for the testing procedure:

| Step | Procedure |
|------|---|
| 1 | Fit the crankshaft locking pin. See chap. 12-20-00 section: 7). |
| 2 | With the crankshaft locked, the propeller can be turned by hand 15 or 30 degrees depending on the profile of the dog gears installed. This is the maximum amount of movement allowed by the dog gears in the torsional shock absorption unit. |
| 3 | Turn the propeller by hand back and forth between ramps, taking into consideration the friction torque. No odd noises or irregular resistance must be noticeable during this moment. |
| 4 | Attach a calibrated spring scale to the propeller in distance (L) from the center of the propeller. Measure the force required to pull the propeller through the 15 or 30 degree range of free rotation. |
| 5 | Calculate friction torque (Nm) by multiplying the force (N) obtained on the spring scale by the distance the scale is attached from the center of the propeller (L). The friction torque must be between 30 Nm and max. 60 Nm (22 to 44.3 ft.lb). See calculation example. NOTICE If the above mentioned friction torque is not achieved, inspect, repair or overhaul the gearbox in accordance with the ROTAX instructions for continued airworthiness. |
| 6 | Remove crankshaft locking pin. See chap. 12-20-00 section: 7). |

d02880.fm

BRP-Powertrain

MAINTENANCE MANUAL

Graphic

Checking the friction torque.

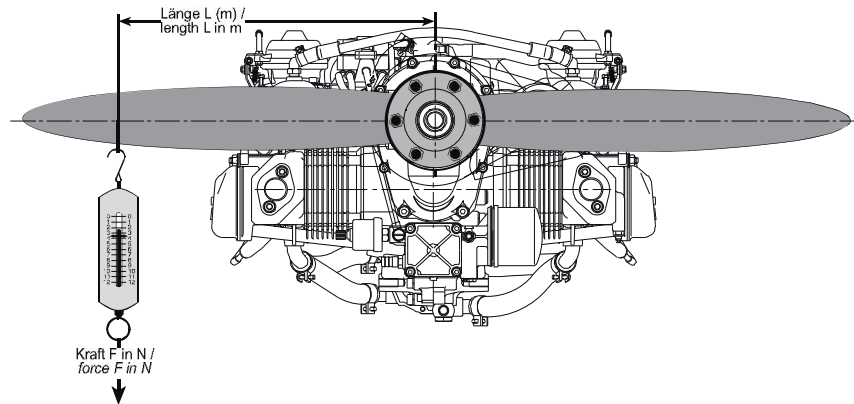

Fig. 31

05694