33T. Braking system - trigear - Matco revised

Overview

The brakes on the trigear Europa are hand or “finger” operated. The main advantage of this system is that the brakes are accessible to both occupants.

The system uses two master cylinders, which are positioned on the right hand side of the central tunnel. A portion of the tunnel is cut away to enable a pre-manufactured fibreglass platform to be mounted; a cover is then fitted which replaces the section of tunnel removed.

A hydraulic parking brake is also included.

Note: Please read the whole chapter before cutting anything.

Action

Step I - Marking the tunnel cut-out

Position the cover moulding, F29, in plate against the starboard side of the central tunnel as shown in figure 1.

Mark around the edge with a felt pen type marker. At the top corner of the thigh support, continue the line through as shown on the photo, - don't follow the lug.

Also, mark around the base of the throttle spine, instead of following the locating flange.

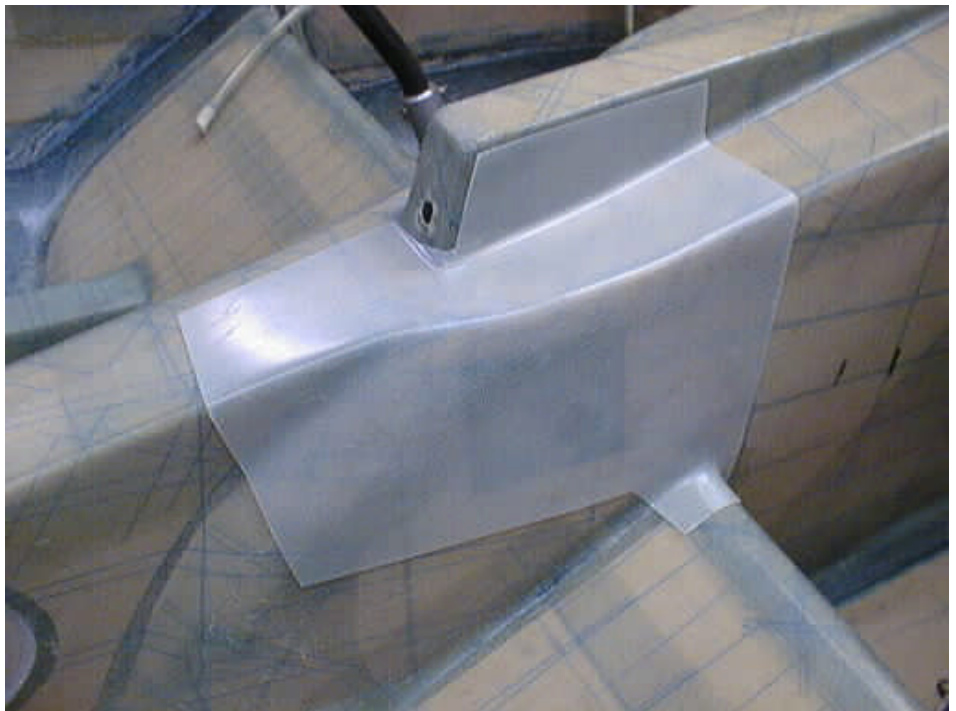

Fig 1. Cover moulding in position.

After removing the cover moulding your cockpit module tunnel should look like the photo in fig 2. this is the initial marking out only, and is NOT to be used for cutting out.

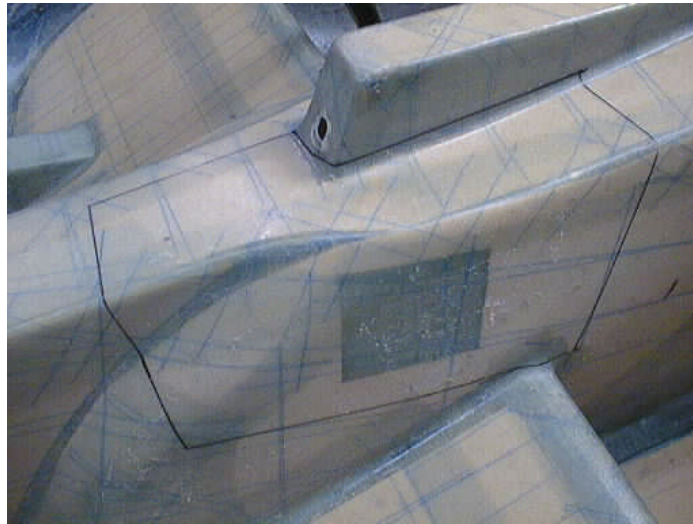

Fig 2. Initial marking lines

Now mark out a second set of lines inside the originals - these should be 15mm (5/8") inside along the bottom and 20mm (3/4") inside along the top and sides. Keep the original line around the throttle spline. See figure 3.

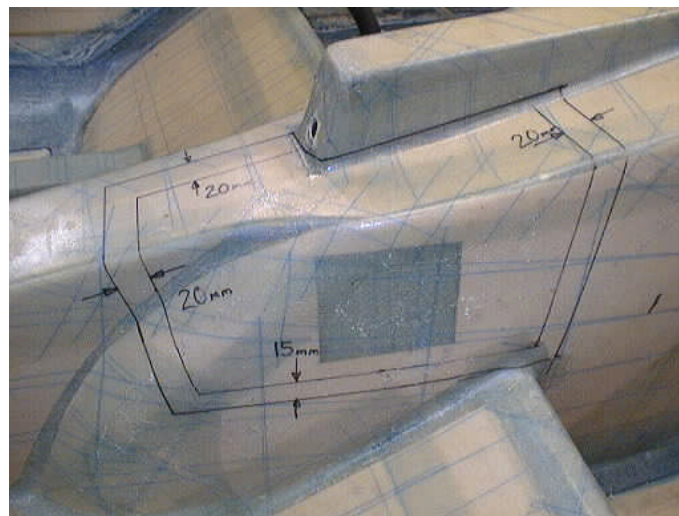

Fig 3. Cutting lines

Step 2 - Cutting out

Now cut out the portion of the tunnel marked by the inside cutting lines, and the line around the base of the throttle spine. See figure 4.

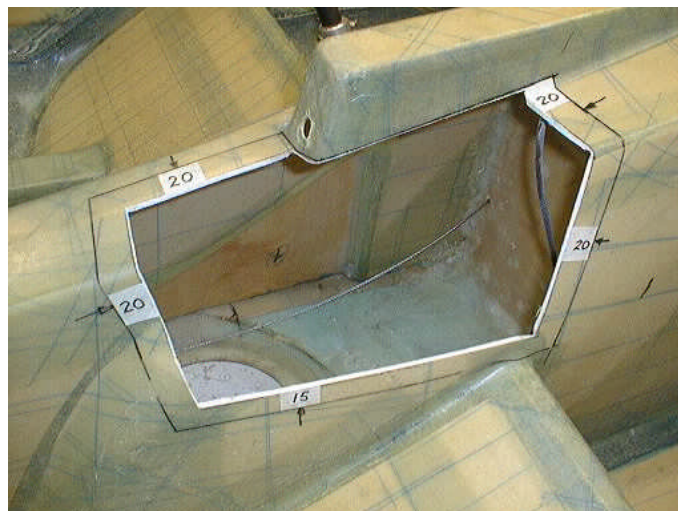

Fig 4. Tunnel after cutting

Step 3 - Exposing flange

Using the original outside lines, cut through the **outer skin only**, then scrape away the foam core, leaving the inner skin intact. This skin is quite thin, so be careful!

Where there is no foam core, you should remove the skin altogether - notice the gaps which can be seen in figure 5.

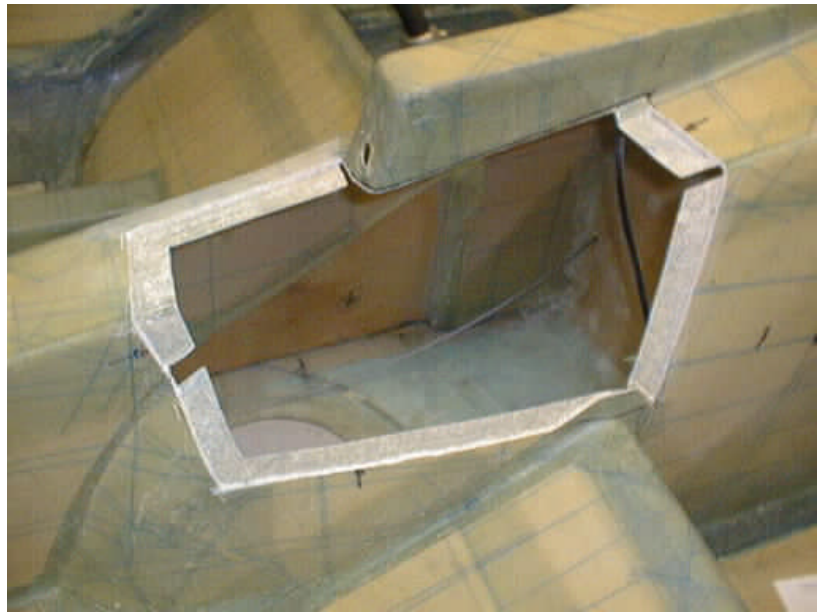

Fig 5. Inner skin exposed.

Step 4 - Cover bolt holes

Eight bolts are used to secure the cover in place as it serves as a structural part.

Before making the bolt holes though, initially trim the edges of the cover such that it fits within the recessed flange of the platform moulding. Initially drill the eight 3mm (1/8") pilot holes into the cover moulding having marked their centres according to the dimensions shown in figure 6.

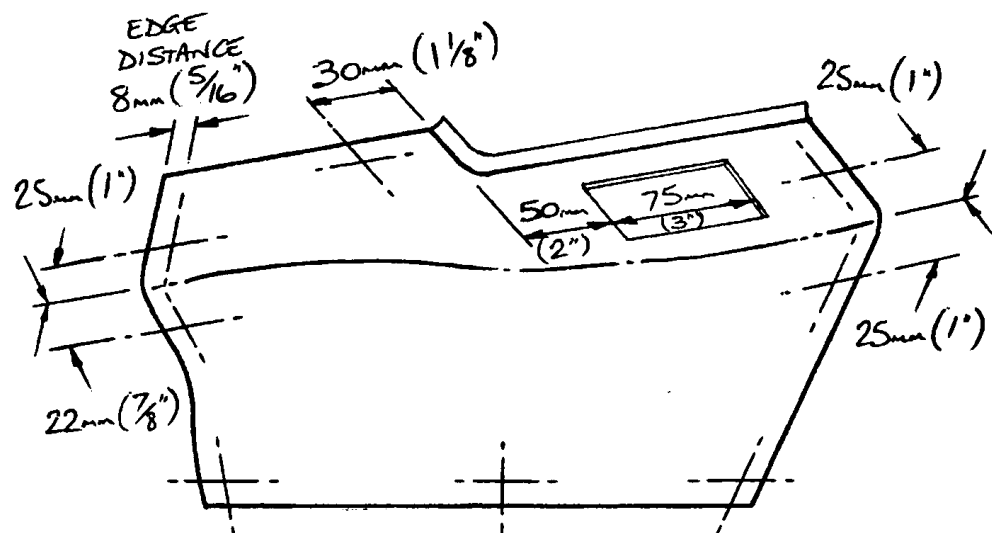

Fig 6. Cover bolt hole centres.

Next, position the platform moulding (F28) into the cockpit module and secure it from moving by drilling two or three 3.3mm(1/8") holes through its outer flange and using Clecos.

Now position the cover onto the platform moulding, locating it within the recessed flange. Hold it in place using adhesive backed tape and drill right through the eight small holes with a 4.8mm drill before removing all the parts from the cockpit module. The flange of the cockpit module is very flexible so do not apply too much pressure as you drill through. Although not essential, you may reinforce this flange with a ply of 'bid'.

Using an MS21051-3 single leg anchor nut as a drill guide, drill the two 2.4mm (3/32") rivet holes for each hole into the thin glass fibre flange. Set the anchor nut at an angle so that at least one of the rivets will have a good edge distance.

Rivet each anchor nut to the underside of the flange using TAPK33BS rivets and EUR063 washers to prevent them pulling through the glassfibre. Don't try to countersink the flange as it is too thin. There will be an adhesive filled gap between the platform moulding and the flange so the rivet heads being proud is not a problem.

A rectangular shaped hole is required in the top of the cover to allow the levers through. Covering this hole will be a metal slotted plate onto which the 'BRAKES - PULL ON' placard is to be mounted. This plate also serves as the mounting plate for the parking brake valve. Cut the hole into the cover according to the dimensions shown in figure 6. The opening is to be wide enough to allow approximately 3mm(1/8") clearance outside of the levers so you'll have to have the master cylinder assembly fitted, therefore this is what is to be done next.

Step 5 -Master cylinder platform

Cut a slot in the rear of the platform 10mm (3/8") wide with centreline 57mm (2 1/4") above the base to allow the hydraulic hoses to pass through. Stick the paper template to the base of the platform, matching as closely as possible to the plywood reinforcement. Drill the 5 holes with a 4.8mm drill.

Temporarily assemble the front and rear mounts B15 and B16 onto the platform using AN3-5A bolts and MS21047-3 anchor nuts. Drill part way through one of the lugs of each anchor nut with a 3.3mm drill, then insert a TLPK435BS pop rivet into each hole thus made, and drill the other lugs.

Remove the front and rear mounts and complete the drilling of the holes for the anchor nut rivets. Lightly spin a drill bit of at least 1/4" diameter, (or a 120' countersink bit) in your fingers in the top surface of each hole until the countersink produced allows the rivets to sit flush with the top surface. Rivet the anchor nuts in place, using the TLPK435BS rivets.

Step 6 - Master cylinder assembly

Fit 269P-04x02 elbows to the outlet ports of the master cylinders, and adjust them to point aft. Fit 269P-04x02 elbows to the inlet ports (nearest the piston rods), adjusting them to point forward.

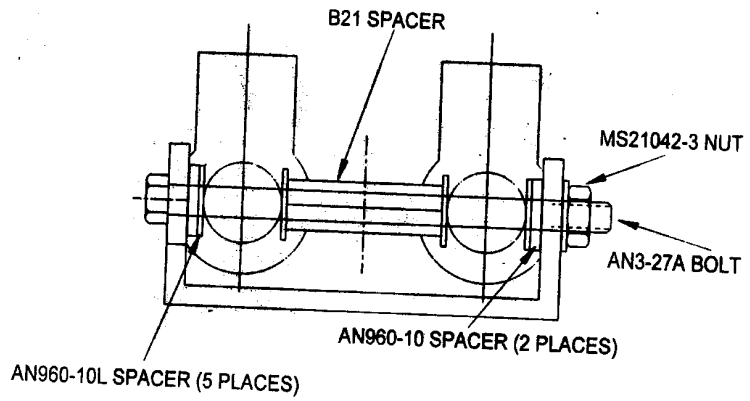

Fig 7. Rear mount assembly

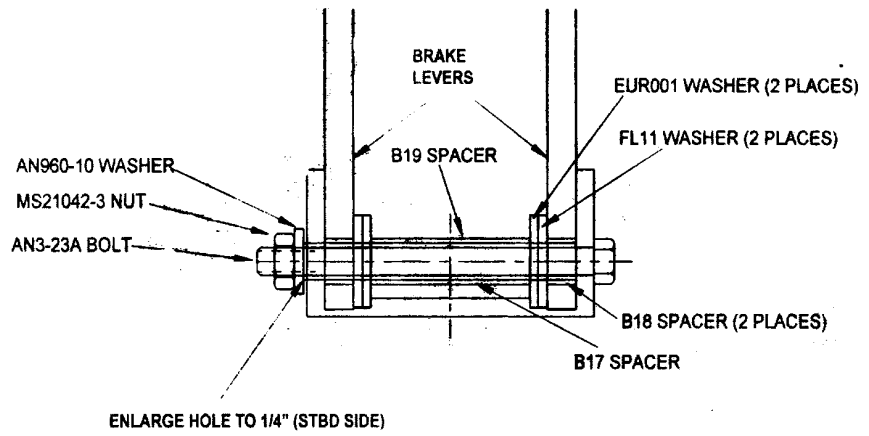

Fig 8. Front mount assembly

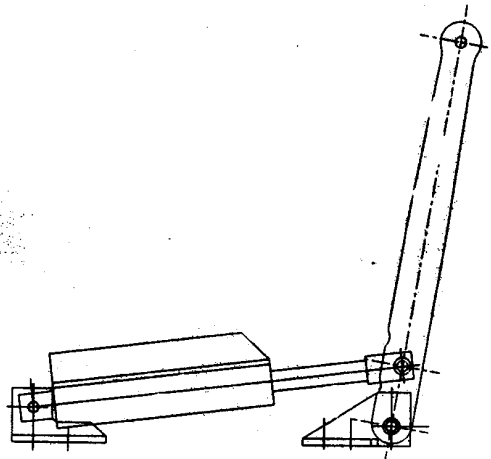

Fig 9. Side view of assembly of master cylinders

Enlarge the hole on the starboard side only of the rear mount B16 to ¼". It may be necessary to chamfer the top forward inside corners of the mount to gain adequate clearance for the master cylinders. Bolt the rear mount to the platform using AN3-5A bolts.

Fully assemble the master cylinders to their mounts as shown in figures 7, 8 and 9.

Bolt the front mount to the platform with AN3-5A bolts.

Fit a short length of brake line to each of the inlet ports and connect them to a 264P-04 'T' piece.

Brake Levers Cover Plate

The double-slotted cover plate for the brake levers is to be held in place using rivets. With the glassfibre cover bolted down, place the cover plate over the brake levers (remove the handles to do this) and position the front of the slots about 3mm (1/8") ahead of the levers. Move the levers fore and aft to ensure that the slots are correctly aligned, then drill through the holes with a 3.2mm drill for TAPD46B S rivets. Attach the plate with the rivets, using EUR 0 11 washers to prevent them pulling through the glassfibre.

NOTE: Before riveting the plate to the cover, bear in mind that you might wish to add upholstery first.

Parking Brake Valve

The parking brake valve provides a means of retaining hydraulic pressure in the lines between each wheel brake caliper and the valve. When the park brake is set to "on" a check valve allows further pressure to be applied by pulling on the brake levers. A lever on the park brake valve, which operates in the same sense as the brake levers - rearwards for "on" - operates the parking brake. This lever, which emerges through a slot in a cover/mounting plate that is on the top of the central tunnel behind the brake levers, is held in the "off" position by a detent in the forward end of the slot.

Step 7 - Parking Brake Lever

The orientation of the parking brake valve is such that the lever is on the starboard side. The assembly of the park brake valve is shown in figure 10. First fit the brake lever extension B23 to the valve using an AN525-10R8 bolt and MS 21042-3 nut through the middle hole of the extension; then drill through the pilot hole and the valve lever with a 4.8mm drill. Fit that hole with an AN525-10R8 bolt and MS21042-3 nut.

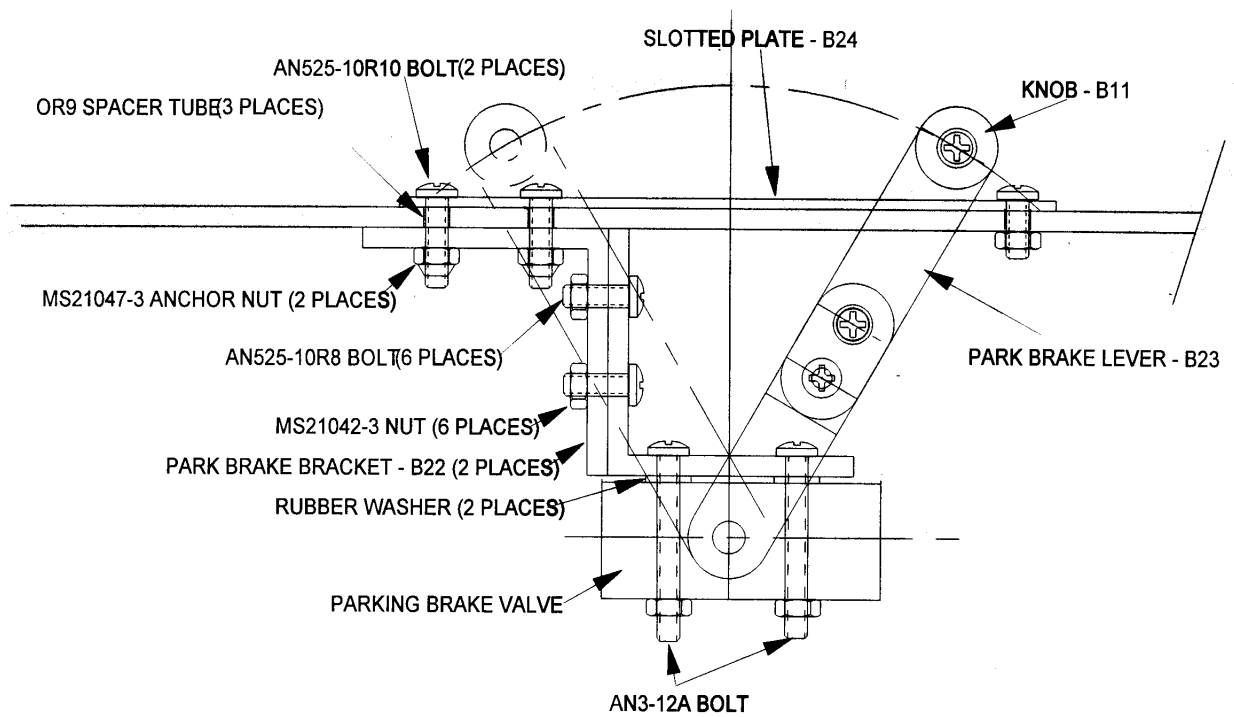

Fig 10. Parking brake valve installation.

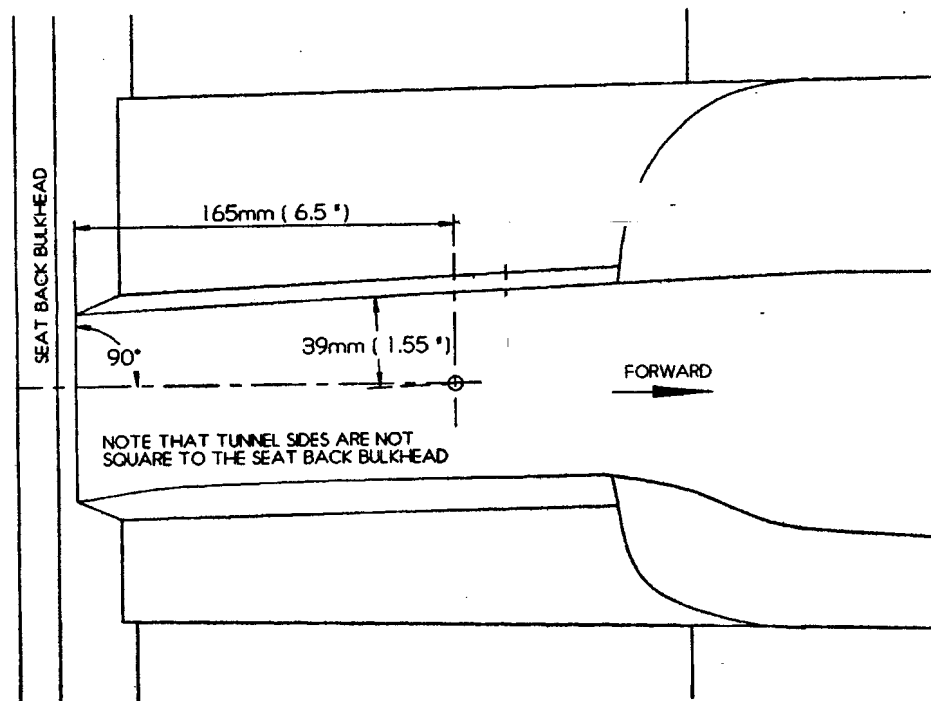

Fig 11. Positioning parking brake mounting/cover plate.

Step 8 - Parking brake valve installation

Working on top of the tunnel, position the mounting/cover plate as shown in figure 11 with the rearmost hole in the position shown, the slot being forward. Mark back the other 2 hole positions and the slot. Remove the cover and cut out the slot and drill the holes in the tunnel top. Fit the valve as shown in figure 10, then fit the lever knob with an AN525-10R8 bolt.

Now attach the two MS21047-3 anchor nuts to the inside face of the mounting bracket using TAPK36BS rivets. Drill the rivet holes to 2.4mm diameter and countersink the outer face of the flange with a drill. Before bolting the mounting bracket to the underside of the tunnel, fit the parking brake valve. When assembling the brackets B22 only 2 of the holes need to be bolted - pick 2 diagonally opposite positions. Fit the valve so that the ports face fore and aft, being careful to include the 2 rubber washers, that are supplied with the park brake valve, in the positions shown between the bottom of the bracket B22 and the top of the valve. See figure 10. Also install 268-04xO2 unions into each of the four ports of the valve. Cut two short pieces of the hydraulic line. Approximately 17cm (6.5") will do. Fit one line each to the fittings that will point forwards. To fit the line, first slide the nut and olive onto the line, push the line onto the spigot of the union, slide forward the nut which will push the olive with it, and screw tighten it.

Next you will install the parking brake valve assembly to the underside of the tunnel, with the lever extension protruding through the slot as you do so using AN525-1 0R1 0 bolts for the rear two positions, and AN525-10R8 for the front position. To prevent the foam core from being crushed though, insert an OR9 spacer tube into each bolt hole first and secure them in with rapid epoxy when you're sure that the holes are correctly spaced from each other.

Place the master cylinder platform, complete with its master cylinder, in place feeding the short hydraulic lines from the parking brake valve through the slot. Cut these lines to length ready for final fitting, then remove the platform.

Step 9 - Brake lines from disc callipers

If you have already run the brake lines from the wheels into the fuselage centre tunnel area go straight to the next paragraph, otherwise refer to the build manual for the relevant instructions. It is not crucial which wheel brake is connected to which park brake valve port, however for ease of maintenance, or trouble shooting a sticking brake, for example, it would be sensible to connect the starboard brake to the starboard side of the valve and vice versa.

Cut the lines to the appropriate length such that they tend to continuously rise from where they emerge through the baggage bay. Avoid loops if at all possible to ease the bleeding of air from the system later on. Connect the lines to the bottom ports of the park brake valve ensuring that the knurled nuts are tight.

Note: The detent part of the slot provides a means of locking the lever in the "off" position. To set the parking brake, the lever needs to be sprung inboard before it is moved aft. Slide the lever fore and aft to check that the lever is correctly held in the "off" position. If necessary adjust the slot by filing.

Drill two 4.8-5.0mm holes through the 'Park Brake' placard and then secure the placard using two AN525-1OR10 bolts, MS21042-3 nuts and AN970-3 Washers.

Step 10 - Reservoir installation

The reservoir is fitted in the engine bay to enable easy access for fluid level checking and replenishment. Its precise position is up to you, but avoid placing it where any spilled hydraulic fluid could drip onto anything and do damage.

Screw a 268-04xO2 union fitting into the bottom port of the reservoir, ensuring that it is fully tight.

Two AN3-4 A bolts are used to install the reservoir with an AN970-3 washer each side of the firewall. These screw directly into the threaded holes in its body.

Bolting through the firewall does mean that you should have access to the rear face of the firewall. If you do not wish to remove an already fitted instrument panel the following method of fitting the reservoir may be used. The parts required are not supplied however.

From a flat strip of steel, size approximately 1.5mm (1/16") thick and 2.5cm x 12.5cm (1"x5"), joggle the central 70mm (2 3/4) to be offset from the ends approximately 6-7mm (1/4"). Drill four 4.8-5mm holes into your new mounting bracket, two in the central part to match the holes in the reservoir, and one in each lug to bolt it to the firewall with. Hold the bracket against the firewall in the position you want the reservoir to be mounted and drill through the two end mounting bolt holes. Enlarge the holes in the firewall to be 1/4" then install MS21047-3 anchor nuts from the front face but with their body protruding into the firewall. Rivet them in place using TLPD419BS rivets.

Mount the bracket to the reservoir first, then bolt the assembly to the firewall using AN3-3A bolts.

Step 11 - Routing hydraulic lines

The hydraulic line between the 'T' piece at the inlets to the master cylinders is to be connected to the reservoir. From the 'T' piece, curve the line to the port side (rather than down and underneath the platform), looping it around to route forwards, trying to avoid curves or loops that may cause air traps.

Find a suitable exit point through the steel firewall and, having cut it to length, fit the line to the bottom of the reservoir. Check that the line will not chafe against anything, and secure it at regular intervals using cable ties or similar.

Step 12 - Bonding platform in place

To prevent adhesive getting into the threads of the anchor nuts when the platform is bonded into place, fill them with plasticine (modelling putty that doesn't set hard) ensuring that you don't contaminate the flange surface when you do so.

Before the platform is bonded into place, scuff sand the bonding areas thoroughly. The platform has a joggle in its bonding flange; the outer part bonds to the tunnel outer skin, and the inboard area bonds to the inner skin of the tunnel. Mix up a quantity of epoxy with flox (Araldite 420 may also be used). Feeding the short hydraulic lines through the slot and attaching them to the two outer fittings of the master cylinder, bond the platform in place, holding it with weights, Clecos, or any other suitable means. Scrape away excess adhesive and allow to cure.

Step 13- Installing the fluid

Use aircraft hydraulic fluid to specification MilH-5606 . (DOT 5 may also be used, but not DOT 3, DOT4, or DOT5.1).

It is probably best to install the hydraulic fluid from the wheel callipers, so that it pushes the air up and ahead of it.

If you have access to a proper brake fluid pump, then use this to inject the fluid from the bleed nipple on the brake calliper. Otherwise you may find that an empty and thoroughly clean plastic bottle, similar to those used for washing-up liquid, will do the job just as well. After fitting the bottle with fluid, attach a small bore flexible pipe (ideally transparent) to the bottle, squeeze fluid into the pipe and, before it comes out of the end, connect it to the bleed nipple.

Ensure that the parking brake valve is set to “OFF” and that the plug or lid is off the reservoir. It has been found that it is best to pull and hold aft the brake lever of the brake side that you are NOT bleeding as you carry out the following. This cuts off the port to the opposite wheel brake, and so ensures that the fluid is directed where you want it to go - into the reservoir.

Open the bleed nipple about ¼ to ½ turn and gently squeeze the fluid into the brake system. Close the nipple before you stop pumping to ensure that you don't draw the fluid back out. Continue until you see fluid start to enter the reservoir. Pump just enough in to fill the reservoir approximately ¼ full. Repeat the exercise for the other calliper and fill the reservoir to about ¾ full.

There is bound to be some air remaining in the master cylinder and the brake callipers, so to remove this you will need to pump the brake levers back and forward. As you pull the lever back, open the bleed nipple. Only allow the lever forward after you have closed the nipple.

To avoid ejected fluid going all over the floor, connect a short transparent tube to the bleed nipple and direct it into a container for disposal. You may not see air bubbles initially as the line from the calliper to the master cylinder is probably free from air, but persevere.

Step 14 - System check

With the aircraft chocked, first check that the parking brake valve is in the 'OFF' position. When the braking system is fully purged of air, you should find that each brake lever moves aft a similar amount for a given effort. Any significant difference would indicate that air may still be present. The levers should also return to their fully forward position as you release them. Do not

attempt to taxi the aircraft until the levers behave correctly as described above. Set the parking brake to 'ON' and pull on both levers to pressurise the system.

Remove any chocks and try to move the aircraft by hand, pulling on the lower part of the door surround. You should not be able to move the aircraft. Set the parking brake to 'OFF' and try to move the aircraft again. It should be free to move. After all the above, go through the entire system, checking for leaks at any of the joints, and top up the reservoir as required.