



Introduction

The E-3 universal engine monitor combines in one compact 2.25" format instrument all that is needed to monitor the majority of smaller aircraft engines from two-stroke ultra-light engines to medium sized four strokes such as those from Rotax, Continental and Lycoming. Most automotive engine conversions can also benefit from the use of the E-3 engine monitor.

The E-3 can measure up to 4 EGT/CHT channels, a RPM input, a universal temperature sender input and a universal pressure sender input.

1 Features

- 66 different engine setup configurations possible
- Universal, programmable rev counter (engine RPM) with digital and analog readout, with a programmable high alarm limit
- Programmable engine Hobbs meter (password protected) and running timer (flight timer) with automatic flight log
- Can monitor up to four programmable thermocouple channels for EGT and CHT probes with a user programmable high alarm limit
- A universal temperature sender input with a user programmable low and high alarm limits
- A universal pressure sender input with a user programmable low and high alarm limits
- Maximum recorded values for all measured values are stored in non-volatile memory
- High accuracy: Built in thermocouple linearization curves and cold junction compensation
- Thermocouple temperature probes can be common K, J or E-type thermocouple probes
- Uses standard automotive temperature and pressure senders
- Special Rotax 912/914 engine monitor mode utilizing the standard built in Rotax NTC CHT probes
- Standard 2.25" aircraft enclosure (can be front or rear mounted)
- Rotary control plus 2 independent buttons for easy menu navigation and user input
- External alarm output as well as a red LED illuminates when the alarm has been activated
- Large backlit graphic LCD with adjustable contrast
- On board voltage reversal and over voltage protection for harsh electrical environments
- SMPS (switch mode power supply) for use in both 12V and 24V systems as well as for reduced power consumption
- Light weight design
- Field upgradeable firmware
- 1 year limited warranty

2 E-3 Layout

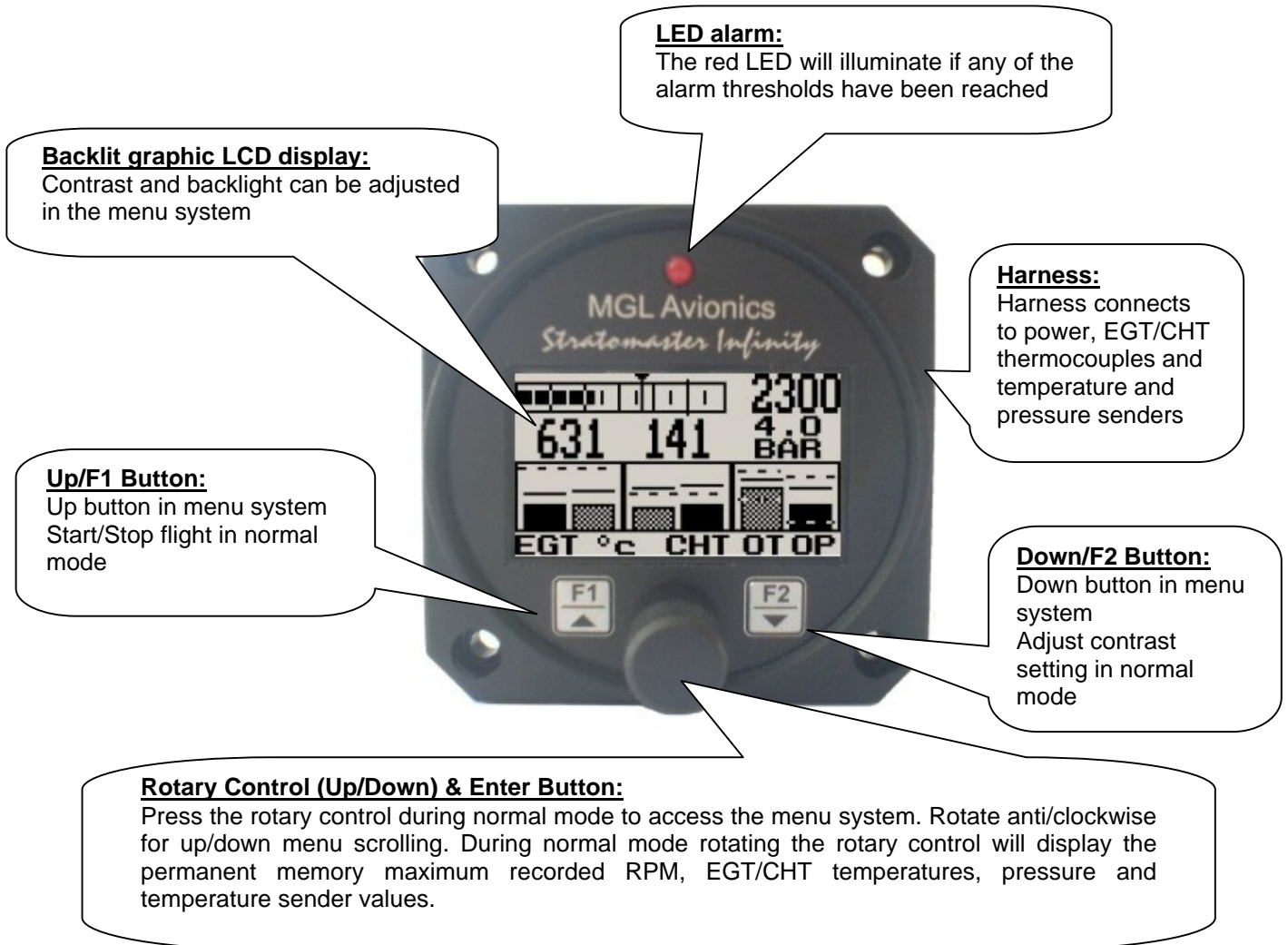

3 Main Display

The E-3 display can be customized to suite your engine measurement requirements. The E-3 will always try and maximize the display area in accordance to the measurement variables selected. The E-3 can be configured to how many EGT and CHT channels you want to display, and whether you want to display a temperature and/or pressure NTC input. All senders can be disabled or enabled.

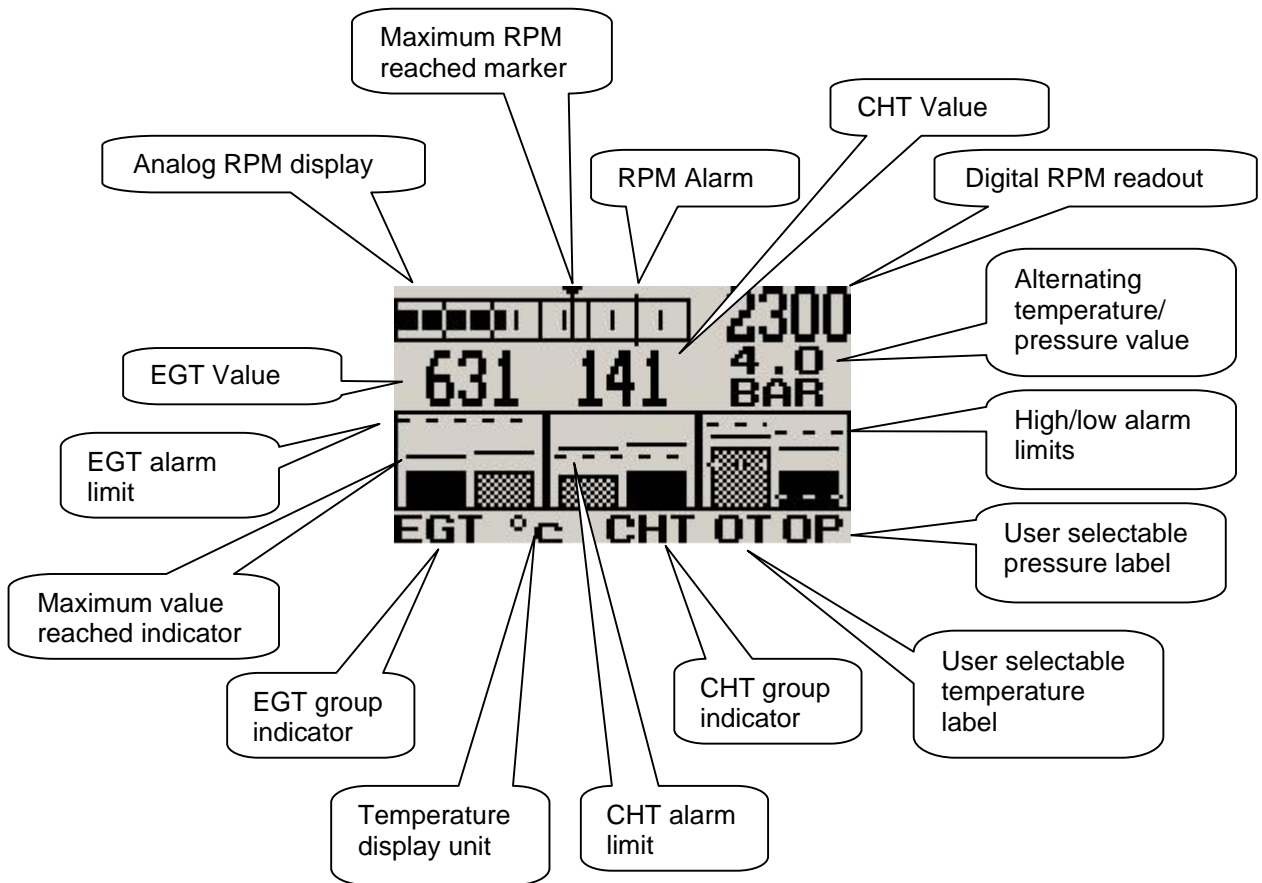

3.1 Flight Time / Hobbs Time

The flight time and Hobbs time displays will alternate at a predetermined interval when the E-3 measures zero RPM.



3.2 Special Rotax 912/914 display mode

In this mode the temperature and pressure NTC inputs becomes CHT channel one and CHT channel 2 respectively. All CHT setups must still be done under the "CHT SETUP" menu. The sender for the temperature and pressure setup must be set for "OFF". A probe setting "NTC" must be selected for the probe setting in the "CHT SETUP" menu. The number of EGT probes can be selected from 0 to 4.

The reason for using the NTC inputs is that the sensors Rotax use are standard NTC temperature probes and not of a thermocouple type.

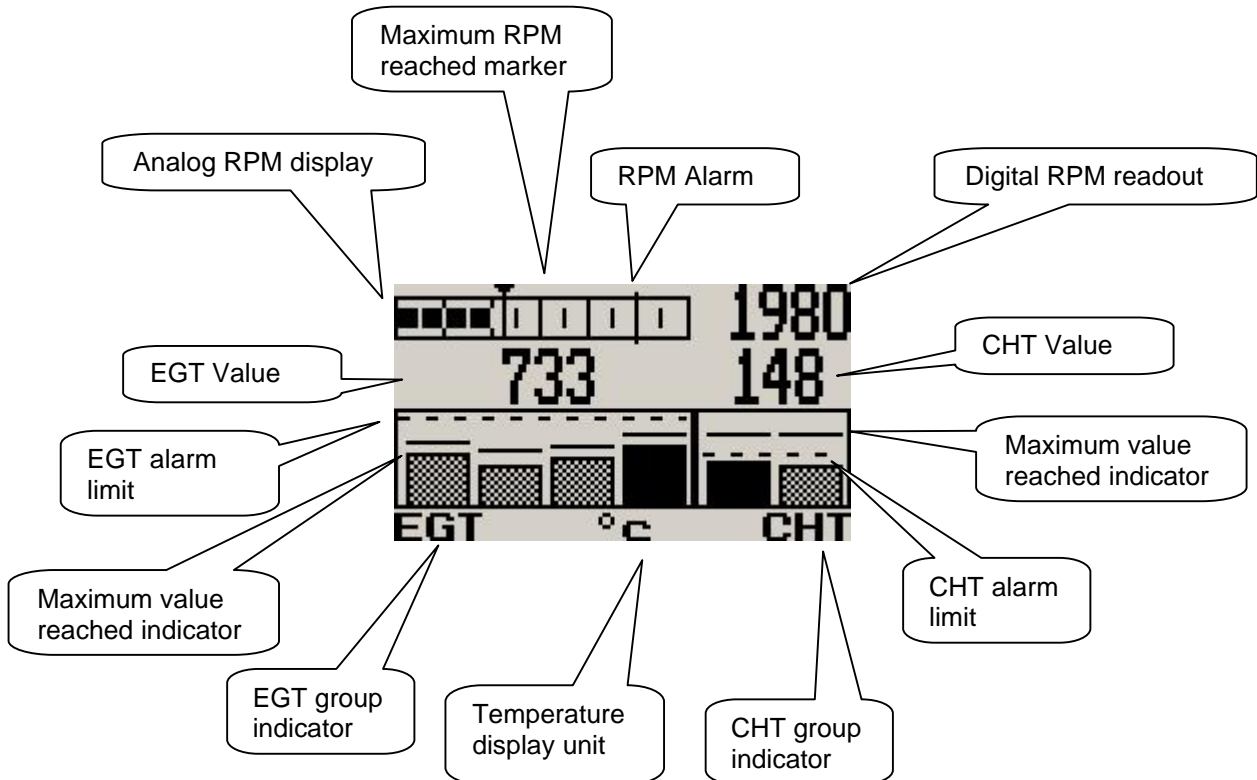

3.3 Start/Stop Flight Display



Press the F1 key during the normal display mode to manually start/stop a flight. This key is only active if the E-3 is setup to select the manual flight option under the "FLIGHT LOG" setup menu.

3.4 Contrast Display

This display can be accessed by pressing the F2 key during the normal display mode. This is a quick access key to the same contrast menu as in the menu system.

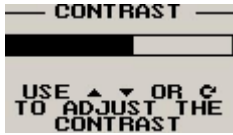

Select this menu option to adjust the display contrast.

3.5 Maximum Values Display

This display can be accessed by rotating the rotary control either clockwise or anticlockwise during the normal display mode. Pressing the F1 key again will reset the maximum values to the current values. Pressing any other key will cause the E-3 to resume to the normal display mode. To avoid false recordings, the maximum values function is only activated 10 seconds after the instrument has powered up.

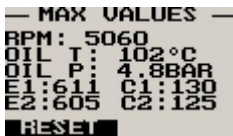

Note: The permanent maximum values are stored in non-volatile memory and are recalled on power-up.

3.6 Maintenance Timer

The purpose of this function is to assist you in determining remaining hours until maintenance will be required. It is not intended as a replacement for the aircraft's maintenance log. It is therefore important that the aircraft's maintenance log be maintained in the normal manner. You should further use your own discretion in performing maintenance earlier than indicated should any aircraft performance problems arise.

A maximum of 999 hours can be entered as a maintenance interval. The E-3 will deduct actual engine running time from the maintenance interval hours as set and will display the reminder message on startup when zero hours are remaining. The reminder message will automatically disappear after 5 seconds or if the pilot presses any key. Engine running time for the purpose of the maintenance timer is defined as the run time where the engine RPM is greater than the preset RPM for the Hobbs meter.

**MAINTENANCE
TIMER HAS
EXPIRED**

4 Menu System

Pressing the rotary control button during the normal display mode will cause the E-3 to enter the menu system. Use the up/down keys or the rotary control to navigate through the menu system.

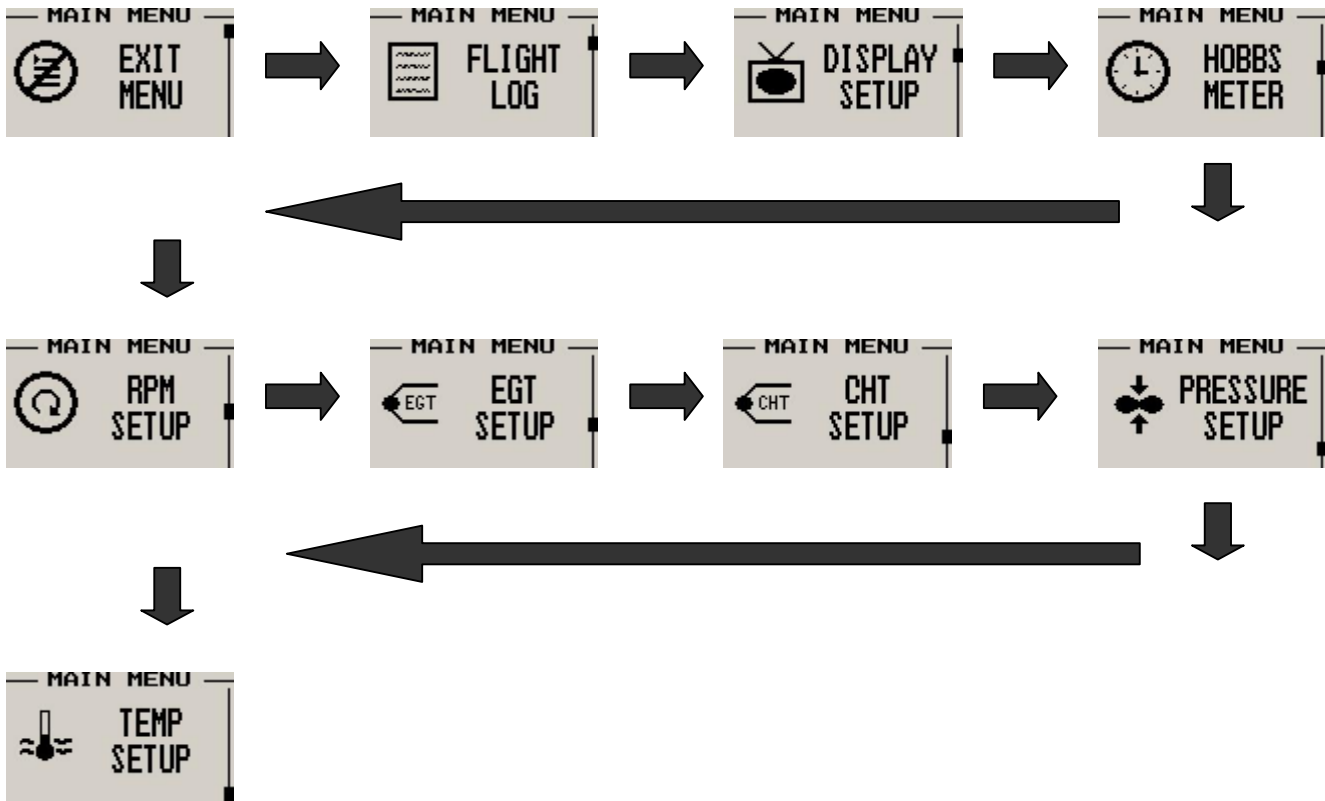

4.1 Exit Menu



Pressing the rotary control on this menu item will cause the E-3 to exit the menu system. All changes made during navigation of the menu system will be saved in non-volatile memory on exiting the menu system. If you remove power before exiting the menu the instrument will not save any changes.

4.2 Flight Log



Select whether the instrument should detect the start and end of flights automatically or if you would like to do this manually. We recommend you select automatic flight detect. With automatic flight detection, flights will start logging when the engine RPM is above the take-off limit. A flight is considered ended when the engine RPM is less than the RPM take-off limit for more than 30 seconds.

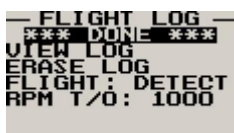

Move the highlight over the “DONE” option and press the rotary button to return to the main menu.

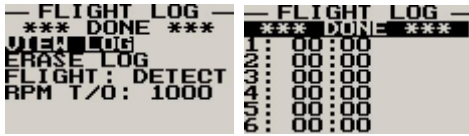

Select this function to view the flight log. The flight log contains the duration of each of the last 24 logged flights. Duration is displayed in hours and minutes. Eight flights are displayed at a time. Use the up/down or the rotary control to navigate through the log. Empty log entries are shown as “-----”.

Note: You cannot select this function while a flight is in progress.



Pressing the F1 key will erase all the flight log entries.



Select whether you want the E-3 to automatically detect a flight or whether the pilot must press the F1 key to start/stop a flight. We recommend you select automatic flight detection.



This menu option is only shown if the “DETECT” flight mode is selected. Enter the engine RPM take-off threshold that you want a flight log entry to start.

4.3 Display Setup



Move the highlight over the “DONE” menu item and press the rotary button to return to the main menu.

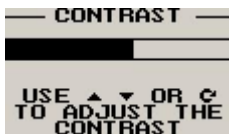

Select this menu option to adjust the display contrast.



Select this menu option to turn the backlight on or off.

4.4 Hobbs Meter

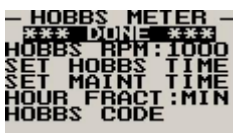

Move the highlight over the “DONE” menu option and press the rotary button to return to the main menu.

```

- HOBBS METER -
*** DONE ***
HOBBS RPM:1000
SET HOBBS TIME
SET MAINT TIME
HOUR FRACT:MIN
HOBBS CODE
    
```

Enter the RPM limit in which the Hobbs meter/maintenance timer must start counting.

```

- HOBBS METER -
*** DONE ***
HOBBS RPM:1000
SET HOBBS TIME
SET MAINT TIME
HOUR FRACT:MIN
HOBBS CODE
    
```

```

USE ▲ ▼ OR C
TO ADJUST THE
HOBBS TIME
0000:00
    
```

This function allows you to set the engine Hobbs meter to any value. Typically, you would use this function to set the Hobbs meter to the current known engine time. Use the up/down or the rotary control to change the value. Press the rotary control to accept and exit the menu option. If the Hobbs code is set to another value beside zero, then the pilot will be prompted to enter the Hobbs access code before allowing him to change the Hobbs time. This feature is useful for chartered and flying school planes.

```

- HOBBS METER -
*** DONE ***
HOBBS RPM:1000
SET HOBBS TIME
SET MAINT TIME
HOUR FRACT:MIN
HOBBS CODE
    
```

```

USE ▲ ▼ OR C
TO ADJUST THE
MAINTENANCE
TIME
000 Hours
    
```

This function allows you to set an engine maintenance timer. This timer is set in engine hours and it will count down to zero when the engine RPM is greater then the Hobbs RPM limit. A good use for this function is to set the hours until your next spark plug change or engine inspection. Use the up/down or the rotary control to change the value. Press the rotary control to accept and exit the menu option.

```

- HOBBS METER -
*** DONE ***
TIME RPM:1000
SET HOBBS TIME
SET MAINT TIME
HOUR FRACT:MIN
HOBBS CODE
    
```

Select if you want your minutes to be displayed as minutes (0-59) or as decimal fractions of a second (00-99) as used in commercial aviation. This setting influences the current flight time display and the flight log.

```

- HOBBS METER -
*** DONE ***
HOBBS RPM:1000
SET HOBBS TIME
SET MAINT TIME
HOUR FRACT:MIN
HOBBS CODE
    
```

This menu option allows you to change the Hobbs access code. You will first be prompted to enter the current code followed by entering in a new code followed by re-entering the new code. If the new code and the re-entered code is the same, then the Hobbs access code will be changed. **Default code is 0000.**

```

ENTER CURRENT
CODE
0000
    
```



```

ENTER NEW
CODE
0000
    
```



```

CONFIRM NEW
CODE
0000
    
```



```

MESSAGE
! CODE
CHANGED
    
```

4.5 EGT (Exhaust Gas Temperature) Setup

```

- MAIN MENU -
EGT
EGT
SETUP
    
```

```

- EGT SETUP -
*** DONE ***
CHANNELS: 2
MODE: HIGHEST
SPAN: 900°C
TOPSCALE: ON
SETPOINT: 850
ALM ON/OFF: ON
    
```

Move the highlight over the “DONE” menu option and press the rotary button to return to the main menu.

```

- EGT SETUP -
*** DONE ***
CHANNELS: 2
MODE: HIGHEST
SPAN: 900°C
TOPSCALE: ON
SETPOINT: 850
ALM ON/OFF: ON
    
```

Select the number of EGT channels you want to use. Choices are from 1 to 4. The temperature display will configure itself to make best possible use of the available display size. Please note that the minimum number of EGT and CHT channels that can be displayed is 1 and the maximum number of EGT and CHT channels that can be displayed is 4.

```

- EGT SETUP -
*** DONE ***
CHANNELS: 2
MODE: HIGHEST
SPAN: 900°C
TOPSCALE: ON
SETPOINT: 850
ALM ON/OFF: ON
    
```

A selection between “HIGHEST” or “SCANNING” can be selected. If “HIGHEST” is selected then the current highest thermocouple temperature is displayed. If “SCANNING” is selected then the unit will cycle through each thermocouple at the time setup under the “DISPLAY SETUP” menu, highlighting it as well as showing its temperature.

```

--- EGT SETUP
*** DONE ***
CHANNELS: 2
MODE: HIGHEST
SPAN: 900°C
TOPSCALE: ON
SETPOINT: 850
ALM ON/OFF: ON
    
```

This function sets the top end of your temperature bar graph. It has no effect on the actual temperature range that can be displayed in the digital temperature readout. Select the range to be just higher than the highest temperature you expect to measure using this channel.

```

--- EGT SETUP
*** DONE ***
CHANNELS: 2
MODE: HIGHEST
SPAN: 900°C
TOPSCALE: ON
SETPOINT: 850
ALM ON/OFF: ON
    
```

Select this function to "ON" if you want the bar graph display to show the upper half of the temperature range only. This results in a higher resolution of the temperature range that you may be interested in. For engine temperature measurements we recommend that you set this to "ON".

```

--- EGT SETUP
*** DONE ***
CHANNELS: 2
MODE: HIGHEST
SPAN: 900°C
TOPSCALE: ON
SETPOINT: 850
ALM ON/OFF: ON
    
```

Adjust the temperature that you would like to use as an alarm limit. Any temperature above this limit will activate the alarm. Active alarms will flash the affected channel and also activate the alarm contact that you can use to switch a lamp on.

```

--- EGT SETUP
*** DONE ***
CHANNELS: 2
MODE: HIGHEST
SPAN: 900°C
TOPSCALE: ON
SETPOINT: 850
ALM ON/OFF: ON
    
```

Select whether you want to turn the alarm on or off. To avoid false activation of the alarms, the alarm function is only activated 10 seconds after the instrument has powered up.

```

--- EGT SETUP
CHANNELS: 2
MODE: HIGHEST
SPAN: 900°C
TOPSCALE: ON
SETPOINT: 850
ALM ON/OFF: ON
PROBE: K-TYPE
    
```

Select if you are using a K-type, J-type or E-type thermocouple probe for this channel. All probes supplied by MGL Avionics are K-Type. J-types are sometimes used with American made CHT probes. All EGT probes are K-type. E-type probes are seldom used.

```

--- EGT SETUP
MODE: HIGHEST
SPAN: 900°C
TOPSCALE: ON
SETPOINT: 850
ALM ON/OFF: ON
PROBE: K-TYPE
TEMP UNIT: °C
    
```

Select whether you want all the temperature values to be displayed in degrees Fahrenheit (°F) or in degrees Celsius (°C).

4.6 CHT (Cylinder Head Temperature) Setup

```

--- MAIN MENU
CHT  CHT
  SETUP
    
```

```

--- CHT SETUP
*** DONE ***
CHANNELS: 2
MODE: HIGHEST
SPAN: 200°C
TOPSCALE: ON
SETPOINT: 150
ALM ON/OFF: ON
    
```

Move the highlight over the "DONE" menu option and press the rotary button to return to the main menu.

```

--- CHT SETUP
*** DONE ***
CHANNELS: 2
MODE: HIGHEST
SPAN: 200°C
TOPSCALE: ON
SETPOINT: 150
ALM ON/OFF: ON
    
```

Select the number of CHT channels you want to use. Choices are from 1 to 4. The temperature display will configure itself to make best possible use of the available display size. Please note that the minimum number of EGT and CHT channels that can be displayed is 1 and the maximum number of EGT and CHT channels that can be displayed is 4.

```

--- CHT SETUP
*** DONE ***
CHANNELS: 2
MODE: HIGHEST
SPAN: 200°C
TOPSCALE: ON
SETPOINT: 150
ALM ON/OFF: ON
    
```

A selection between "HIGHEST" or "SCANNING" can be selected. If "HIGHEST" is selected then the current highest thermocouple temperature is displayed. If "SCANNING" is selected then the unit will cycle through each thermocouple at the time setup under the "DISPLAY SETUP" menu, highlighting it as well as showing its temperature.

```

--- CHT SETUP
*** DONE ***
CHANNELS: 2
MODE: HIGHEST
SPAN: 200°C
TOPSCALE: ON
SETPOINT: 150
ALM ON/OFF: ON
    
```

This function sets the top end of your temperature bar graph. It has no effect on the actual temperature range that can be displayed in the digital temperature readout. Select the range to be just higher than the highest temperature you expect to measure using this channel.

```

--- CHT SETUP ---
*** DONE ***
CHANNELS: 2
MODE: HIGHEST
SPAN: 200°C
TOPSCALE: ON
SETPOINT: 150
ALM ON/OFF: ON
    
```

Select this function to "ON" if you want the bar graph display to show the upper half of the temperature range only. This results in a higher resolution of the temperature range that you may be interested in. For engine temperature measurements we recommend that you set this to "ON".

```

--- CHT SETUP ---
*** DONE ***
CHANNELS: 2
MODE: HIGHEST
SPAN: 200°C
TOPSCALE: ON
SETPOINT: 150
ALM ON/OFF: ON
    
```

Adjust the temperature that you would like to use as an alarm limit. Any temperature above this limit will activate the alarm. Active alarms will flash the affected channel and also activate the alarm contact that you can use to switch a lamp on.

```

--- CHT SETUP ---
*** DONE ***
CHANNELS: 2
MODE: HIGHEST
SPAN: 200°C
TOPSCALE: ON
SETPOINT: 150
ALM ON/OFF: ON
    
```

Select whether you want to turn the alarm on or off. To avoid false activation of the alarms, the alarm function is only activated 10 seconds after the instrument has powered up.

```

--- EGT SETUP ---
CHANNELS: 2
MODE: HIGHEST
SPAN: 90°C
TOPSCALE: ON
SETPOINT: 850
ALM ON/OFF: ON
PROBE: K-TYPE
    
```

Select if you are using a K-type, J-type or E-type thermocouple probe for this channel. All probes supplied by MGL Avionics are K-Type. J-types are sometimes used with American made CHT probes. All EGT probes are K-type. E-type probes are seldom used. If the probe type is set for "NTC" and the temperature and pressure senders are disabled and 1 or 2 CHT channels are selected then the unit will enter a special Rotax 912/914 display mode.

```

--- CHT SETUP ---
MODE: HIGHEST
SPAN: 200°C
TOPSCALE: ON
SETPOINT: 150
ALM ON/OFF: ON
PROBE: J-TYPE
TEMP UNIT: °F
    
```

Select whether you want all the temperature values to be displayed in degrees Fahrenheit (°F) or in degrees Celsius (°C).

4.7 RPM Setup

```

--- MAIN MENU ---
RPM
SETUP
    
```

All the RPM related settings can be setup here.

```

--- RPM SETUP ---
*** DONE ***
SCALE: 6000
ALM ON/OFF: ON
ALARM: 5000
PUL/REV: 6.0
PULSE: PULSE
FILTER: SCALE
    
```

Move the highlight over the "DONE" menu option and press the rotary button to return to the main menu.

```

--- RPM SETUP ---
*** DONE ***
SCALE: 6000
ALM ON/OFF: ON
ALARM: 5000
PUL/REV: 6.0
PULSE: PULSE
FILTER: SCALE
    
```

Select the maximum value that you want the RPM analog bar graph display to show. This can give you increased display resolution.

```

--- RPM SETUP ---
*** DONE ***
SCALE: 6000
ALM ON/OFF: ON
ALARM: 5000
PUL/REV: 6.0
PULSE: PULSE
FILTER: SCALE
    
```

Select whether you want the RPM alarm to be turned on or off.

```

--- RPM SETUP ---
*** DONE ***
SCALE: 6000
ALM ON/OFF: ON
ALARM: 5000
PUL/REV: 6.0
PULSE: PULSE
FILTER: SCALE
    
```

Enter the RPM alarm activation threshold. Any RPM value above this value will activate the alarm.

```

RPM SETUP
*** DONE ***
SCALE: 6000
ALM ON/OFF: ON
ALARM: 5000
PUL/REV: 1.5
PULSE: PULSE
FILTER: SCALE
    
```

Enter the number of pulses per RPM. For engines with an uneven number of cylinders like three cylinder four stroke engines you can enter values containing fractions (usually 1.5 in this example). Most four stroke engines will generate one pulse for every two revolutions per cylinder. A four cylinder automotive four stroke engine will thus generate 2 pulses per revolution. A typical Rotax DCDI two stroke engine will generate 6 pulses per revolution. The well known Rotax 912/914 engine generates one pulse per revolution.

```

RPM SETUP
*** DONE ***
SCALE: 6000
ALM ON/OFF: ON
ALARM: 5000
PUL/REV: 6.0
PULSE: PULSE
FILTER: SCALE
    
```

PULSE: The E-3 counts pulses from the engine for 1/2 second period (fast frequency input).
 TIME: The E-3 uses the time between pulses to calculate revs (slow frequency input).

Typical setups:

- Rotax 503,582 DCDI – Pulse (Fast frequency) (6 pulses per revolution)
- Rotax 503 single ignition, Rotax 912/914 – Time (Slow frequency) (one pulse per revolution)
- Gyro Rotor RPM with gear tooth sensor - Pulse (Fast frequency) (about 100 pulses per revolution)
- Gyro Rotor RPM with single hall-effect sensor – Time (Slow frequency) (one pulse per revolution)
- Helicopter Rotor RPM with single hall-effect sensor – Time (Slow frequency) (one pulse per revolution)

```

RPM SETUP
*** DONE ***
SCALE: 6000
ALM ON/OFF: ON
ALARM: 5000
PUL/REV: 6.0
PULSE: PULSE
FILTER: SCALE
    
```

The E-3 unit contains a digital filter. This filter is used to achieve a higher resolution of the digital rev counter than is available in ordinary operation. In digital rev counters, resolution is largely dependant on the amount of time given to measure RPM. The more time that is available, the higher the resolution will be. However, on the downside of this, the more sluggish the display will react to changes in engine settings. Resolution with the E-3 is dependant on the number of pulses per rev and the type of measurement method you have selected (pulse fast/slow). The update rate for the measurement is a fixed, fast 0.5 seconds. The digital filter is activated whenever input revs are fairly constant and this results in a very high resolution of the digital RPM display in a short time span. The filter needs to be setup for the expected base resolution. This can be between 10 and 30 RPM for most setups. The filter has the following settings:

Scale -The setting is made dependant on your scale selection from 500 to 20000 RPM. The filter factor is fixed as follows:

Scale 500 – 10 RPM	Scale 10000 – 200 RPM
Scale 1000 – 20 RPM	Scale 10500 – 210 RPM
Scale 1500 – 30 RPM	Scale 11000 – 220 RPM
Scale 2000 – 40 RPM	Scale 11500 – 230 RPM
Scale 2500 – 50 RPM	Scale 12000 – 240 RPM
Scale 3000 – 60 RPM	Scale 12500 – 250 RPM
Scale 3500 – 70 RPM	Scale 13000 – 260 RPM
Scale 4000 – 80 RPM	Scale 13500 – 270 RPM
Scale 4500 – 90 RPM	Scale 14000 – 280 RPM
Scale 5000 – 100 RPM	Scale 14500 – 290 RPM
Scale 5500 – 110 RPM	Scale 15000 – 300 RPM
Scale 6000 – 120 RPM	Scale 15500 – 310 RPM
Scale 6500 – 130 RPM	Scale 16000 – 320 RPM
Scale 7000 – 140 RPM	Scale 16500 – 330 RPM
Scale 7500 – 150 RPM	Scale 17000 – 340 RPM
Scale 8000 – 160 RPM	Scale 17500 – 350 RPM
Scale 8500 – 170 RPM	Scale 18000 – 360 RPM
Scale 9000 – 180 RPM	Scale 18500 – 370 RPM
Scale 9500 – 190 RPM	Scale 19000 – 380 RPM

10,20,30,40,50,60,70,80,90,100 – The filter factor can be set to any of these values independent of your scale selection. Choose a filter setting that results in a smooth, high resolution RPM display. A filter setting too low for your setup will result in a “jumpy” display. RPM display will change at your base resolution and no smoothing will happen. Choose the lowest setting that will result in a smooth display for greatest sensitivity of the reading.

4.8 Pressure Setup



The pressure setup menu item allows the user to adjust the pressure sender properties.



Move the highlight over this menu item and press the rotary button to return to the main menu.



Select whether to use the pressure sender or not.

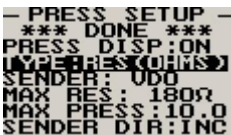

Select if you are using a resistive or a linear voltage output pressure sender.

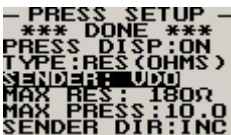

Select what type of pressure sender you are using. Select “VDO” for VDO/Resistive pressure senders or “USER” for a custom sender. This menu item is fixed on “USER” if the linear pressure type is selected.

If the “Resistive” pressure sender is selected



Enter the maximum resistance of your pressure sender. Common VDO pressure senders are typically 180 Ohms.



Enter the maximum pressure for your pressure sender. If you are using a VDO 10 bar pressure sender then enter in 10.0, if you are using a VDO 5 bar, then enter in 5.0, if you are using a VDO 2 bar then enter in 2.0. Enter the maximum pressure in the selected unit VDO 10BAR = 145PSI.



Select whether your pressure sender increases resistance with pressure or decreases resistance with pressure. VDO senders normally increase resistance with pressure.

If the “User” pressure sender is selected

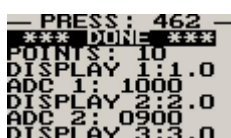

If the sender type is set to “USER”, then use this menu option to calibrate your temperature sender. See section 4.9.1 for more information.

Menu options for all sender types

```

- PRESS SETUP -
PRESS DISP:ON
TYPE:RES(OHMS)
SENDER: VDO
MAX RES: 180Ω
MAX PRESS:10.0
SENDER DIR:INC
LABEL: OIL
UNIT: BAR

```

Choose one of a selection of labels to suit your pressure input so you can identify it easily.

```

- PRESS SETUP -
TYPE:RES(OHMS)
SENDER: VDO
MAX RES: 180Ω
MAX PRESS:10.0
SENDER DIR:INC
LABEL: OIL
UNIT: BAR

```

Select whether you want to display the pressure in Bar, PSI or PSI(0.1). The PSI(0.1) is for low range pressure senders e.g. 7PSI.

```

- PRESS SETUP -
SENDER: VDO
MAX RES: 180Ω
MAX PRESS:10.0
SENDER DIR:INC
LABEL: OIL
UNIT: BAR
SPAN: 10.0 BAR

```

Set the range of the pressure sender. This is the maximum that the bargraph display will go to.

```

- PRESS SETUP -
MAX RES: 180Ω
MAX PRESS:10.0
SENDER DIR:INC
LABEL: OIL
UNIT: BAR
SPAN: 10.0 BAR
TOPSCALE: OFF

```

This allows the user to zoom into the top half of the bar graph resulting in a higher display resolution. This option set to "ON" is recommended.

```

- PRESS SETUP -
MAX PRESS:10.0
SENDER DIR:INC
LABEL: OIL
UNIT: BAR
SPAN: 10.0 BAR
TOPSCALE: OFF
ALM LOW: ON

```

Select whether to use the low pressure alarm.

```

- PRESS SETUP -
SENDER DIR:INC
LABEL: OIL
UNIT: BAR
SPAN: 10.0 BAR
TOPSCALE: OFF
ALM LOW: ON

```

Use this to set the low pressure alarm set-point.

```

- PRESS SETUP -
LABEL: OIL
UNIT: BAR
SPAN: 10.0 BAR
TOPSCALE: OFF
ALM LOW: ON
ALM LOW: 1.5
ALM HIGH: ON

```

Select whether to use the high pressure alarm.

```

- PRESS SETUP -
UNIT: BAR
SPAN: 10.0 BAR
TOPSCALE: OFF
ALM LOW: ON
ALM LOW: 1.5
ALM HIGH: ON

```

Use this to set the high pressure alarm set-point.

4.9 Temperature Setup

```

- MAIN MENU -
TEMP SETUP

```

The temperature setup menu item allows the user to adjust the temperature sender properties.

```

- TEMP SETUP -
*** DONE ***
TEMP DISP: ON
SENDER: VDO
LABEL: OIL
UNIT: °C
SPAN: 150°C
TOPSCALE: ON

```

Move the highlight over this menu item and press the rotary button to return to the main menu.

```

- TEMP SETUP -
*** DONE ***
TEMP DISP: ON
SENDER: VDO
LABEL: OIL
UNIT: °C
SPAN: 150°C
TOPSCALE: ON

```

Select whether to use the temperature sender or not.

```

TEMP SETUP
*** DONE ***
TEMP DISP: ON
SENDER: VDO
LABEL: OIL
UNIT: °C
SPAN: 150°C
TOPSCALE: ON
    
```

Select what type of sender you are using. Select “VDO” for VDO/NTC senders, “ECHLIN” (Echlin TS920SA temperature sender), LM335 for the MGL precision temperature sender or “USER” for a custom sender. The E-3 has a built in linearization curve for a standard 50°C to 150°C VDO sender as used in a Rotax 912 engine.

If the sender type is set to “User”

```

TEMP SETUP
*** DONE ***
TEMP DISP: ON
SENDER: USER
LABEL: OIL
UNIT: °C
SPAN: 150°C
    
```

```

TEMP: 96.9
*** DONE ***
POINTS: 10
DISPLAY 1: 010
ADC 1: 1000
DISPLAY 2: 020
ADC 2: 0900
DISPLAY 3: 030
    
```

If the sender type is set to “USER”, then use this menu option to calibrate your temperature sender. See section 4.9.1 for more information.

If the sender type is set to “LM335”

```

TEMP SETUP
*** DONE ***
TEMP DISP: ON
SENDER: LM335
LABEL: OIL
UNIT: °C
SPAN: 150°C
    
```

If the sender type is set to LM335, then use this menu option to calibrate your LM335 precision temperature sender. If recalibration is required then adjust the value using the up/down keys or the rotary control until the temperature matches the reference ambient temperature. Please note that the LM335 can only be calibrated in degrees Celcius irrespective if the E-3 is setup to display temperature in Fahrenheit.

Menu options for all sender types

```

TEMP SETUP
*** DONE ***
TEMP DISP: ON
SENDER: VDO
LABEL: OIL
UNIT: °C
SPAN: 150°C
TOPSCALE: ON
    
```

Choose one of a selection of labels to suit your temperature input so you can identify it easily.

```

TEMP SETUP
*** DONE ***
TEMP DISP: ON
SENDER: VDO
LABEL: °F
UNIT: °F
SPAN: 150°C
TOPSCALE: ON
    
```

Select whether you want the temperature to be displayed in degrees Celcius (°C) or in degrees Fahrenheit (°F).

```

TEMP SETUP
*** DONE ***
TEMP DISP: ON
SENDER: VDO
LABEL: OIL
UNIT: °C
SPAN: 150°C
TOPSCALE: ON
    
```

Set the range of the temperature sender. This is the maximum that the bargraph display will go to.

```

TEMP SETUP
*** DONE ***
TEMP DISP: ON
SENDER: VDO
LABEL: OIL
UNIT: °C
SPAN: 150°C
TOPSCALE: ON
    
```

This allows the user to zoom into the top half of the bar graph resulting in a higher display resolution. This option set to “ON” is recommended.

```

TEMP SETUP
TEMP DISP: ON
SENDER: VDO
LABEL: OIL
UNIT: °C
SPAN: 150°C
TOPSCALE: ON
ALARM LOW: ON
    
```

Select whether to use the low temperature alarm.

```

TEMP SETUP
SENDER: VDO
LABEL: OIL
UNIT: °C
SPAN: 150°C
TOPSCALE: ON
ALARM LOW: ON
ALARM LOW: 70
    
```

Use this to set the low temperature alarm set-point.

```

TEMP SETUP
LABEL: OIL
UNIT: °C
SPAN: 150°C
TOPSCALE: ON
ALARM LOW: ON
ALARM LOW: 70
ALARM HIGH: ON
    
```

Select whether to use the high temperature alarm.

```

TEMP SETUP
UNIT: °C
SPAN: 150°C
TOPSCALE: ON
ALARM LOW: ON
ALARM LOW: 70
ALARM HIGH: ON
ALARM HIGH: 165
    
```

Use this to set the high temperature alarm set-point.

4.9.1 Calibrating the user defined pressure and temperature sender

```

PRESS: 462
*** DUN: ***
POINTS: 10
DISPLAY 1:1.0
ADC 1: 1000
DISPLAY 2:2.0
ADC 2: 0900
DISPLAY 3:3.0
    
```

```

TEMP: 969
*** DUN: ***
POINTS: 10
DISPLAY 1:010
ADC 1: 1000
DISPLAY 2:020
ADC 2: 0900
DISPLAY 3:030
    
```

1. Enter the number of points that you want to calibrate.
2. Enter the display reading that you want to show when the sender is at that actual display reading.
3. Enter the ADC (analog to digital converter) reading that corresponds to this display reading. The ADC reading is shown at the top of the calibration menu if you are applying the actual stimulus from the temperature or pressure sender. You can also manually enter this value if the ADC value is known or pre-calculated.
4. Continue entering display and ADC values until all the points have been entered.
5. Verify the above calibration by checking the temperature/pressure display versus the actual applied sender stimulus.

5 Engine configurations

The E-3 supports 66 different engine configurations. See the table below.

EGT				CHT				Pressure	Temperature	RPM
1	2	3	4	1	2	3	4			
X										X
	X									X
		X								X
			X							X
				X						X
					X					X
						X				X
							X			X
X				X						X
X					X					X
X						X				X
	X			X						X
	X				X					X
		X		X						X
			X					X		X
									X	X
X								X		X
	X							X		X
		X						X		X
			X					X		X
				X				X		X
					X			X		X
						X		X		X
							X	X		X
X				X				X		X
X					X			X		X

7 Operating the alarms

If the alarm is activated, the corresponding item on the display will flash. At the same time the externally available alarm switch will close. The switch will remain closed until any button is pressed to acknowledge the alarm or until the condition(s) that activated the alarm no longer exist. The alarm output can be used to switch an external alarm indicator. The external alarm switch is an open collector transistor switch to ground with a maximum rating of 0.5A DC. It is possible to wire the alarm contacts of several Stratomaster Infinity instruments in parallel should this be desired. To avoid false activation of the alarms, the alarm function is only active 10 seconds after the instrument has powered up.

8 Cleaning

The unit should not be cleaned with any abrasive substances. The screen is very sensitive to certain cleaning materials and should only be cleaned using a clean, damp cloth.

Warning: The E-3 is not waterproof. Serious damage could occur if the unit is exposed to water and/or spray jets.

9 E-3 Specifications

Operating Temperature Range	-10°C to 50°C (14°F to 122°F)
Storage Temperature Range	-20°C to 80°C (-4°F to 176°F)
Humidity	<85% non-condensing
Power Supply	8 to 30Vdc SMPS (switch mode power supply) with built in 33V over voltage and reverse voltage protection
Current Consumption	approx. 30mA @ 13.8V (backlight on) 15mA @13.8V (backlight off)
Display	114x64 graphic LCD display. Contrast and backlight is user configurable, green/yellow backlight
Dimensions	60mmx60mmx61mm (2.36"x2.36"x2.40") (see Infinity series dimensional drawing)
Enclosure	2.25" ABS, black in color, front or rear mounting
Weight	Approx. 85 grams
Alarm contact current rating	Open collector transistor switch to ground. Maximum rating 0.5A DC
Non-volatile memory storage	100000 write cycles
RPM	
Rev counter input	Range: 0-20000 RPM. Minimum signal for stable display: 5Vpp. Fully A/C coupled, maximum voltage +/- 40V RF noise filter plus Schmitt-trigger based input
EGT/CHT	
Thermocouples	K-type or J-type
Measurement range	J-Type: -210°C to 1200°C (-346°F to 2192°F) K-Type: -270°C to 1370°C (-454°F to 2498°F) E-Type: -270°C to 900°C (-454°F to 1652°F)
Technology	Fully cold junction compensated using precision internal temperature reference,

	built in thermocouple linearization tables
Measurement accuracy	+/- 5 degrees typical over full temperature range, subject to quality of probe used.
Inputs	Differential, can use grounded and isolated probes
Common mode voltage range	-2V to +3V

Temperature Sender

Temperature sensors	<p>VDO: Standard 50°C to 150°C temperature sender as fitted to Rotax 912/914 engines.</p> <p>VDO Temperature (°C) /Resistance curve for a standard 50°C to 150°C sender</p> <table border="1"> <thead> <tr> <th>Temperature (°C)</th> <th>Resistance (Ohms)</th> </tr> </thead> <tbody> <tr><td>50</td><td>322.8</td></tr> <tr><td>66</td><td>179.5</td></tr> <tr><td>80</td><td>112.5</td></tr> <tr><td>100</td><td>62.2</td></tr> <tr><td>110</td><td>48.1</td></tr> <tr><td>120</td><td>36.5</td></tr> <tr><td>130</td><td>28.9</td></tr> <tr><td>140</td><td>23.1</td></tr> <tr><td>150</td><td>18.6</td></tr> </tbody> </table> <p>ECHLIN: Echlin TS920SA automotive temperature sender</p> <p>MGL Precision semiconductor (LM335): Based on National Semiconductor LM335 temperature sensor</p> <p>User defined senders: The E-3 has a user sender calibration feature that can be customized for senders not listed above</p>	Temperature (°C)	Resistance (Ohms)	50	322.8	66	179.5	80	112.5	100	62.2	110	48.1	120	36.5	130	28.9	140	23.1	150	18.6
	Temperature (°C)	Resistance (Ohms)																			
50	322.8																				
66	179.5																				
80	112.5																				
100	62.2																				
110	48.1																				
120	36.5																				
130	28.9																				
140	23.1																				
150	18.6																				

Pressure Sender

Pressure sensors	<p>VDO: Standard VDO pressure senders (as fitted to a Rotax 912/914 engine) VDO pressure senders used to measure fuel pressure require the fuel isolation kit available from VDO.</p> <p>Linear pressure senders: Linear types with a 0V-5V range are supported, pull-up resistor in instrument is 1k5 Ohms.</p> <p>User defined senders: The E-3 has a user sender calibration feature that can be customized for senders not listed above.</p> <p>VDO Bar/Resistance curve for a 10 Bar pressure sender</p> <table border="1"> <thead> <tr> <th>Pressure (Bar)</th> <th>Resistance (Ohms)</th> </tr> </thead> <tbody> <tr><td>0</td><td>10</td></tr> <tr><td>2</td><td>51</td></tr> <tr><td>4</td><td>86</td></tr> <tr><td>6</td><td>122</td></tr> <tr><td>8</td><td>152</td></tr> <tr><td>10</td><td>180</td></tr> </tbody> </table>	Pressure (Bar)	Resistance (Ohms)	0	10	2	51	4	86	6	122	8	152	10	180
	Pressure (Bar)	Resistance (Ohms)													
0	10														
2	51														
4	86														
6	122														
8	152														
10	180														

10 Installation

10.1 General Connection Diagram

The use of an external 1A fuse is recommended. Connect the supply terminals to your aircraft's power supply. The E-3 can be used on both 12V and 24V without the use of any pre-regulators. Ensure that the supply voltage will not drop below 8V during operation as this may result in incorrect displays.

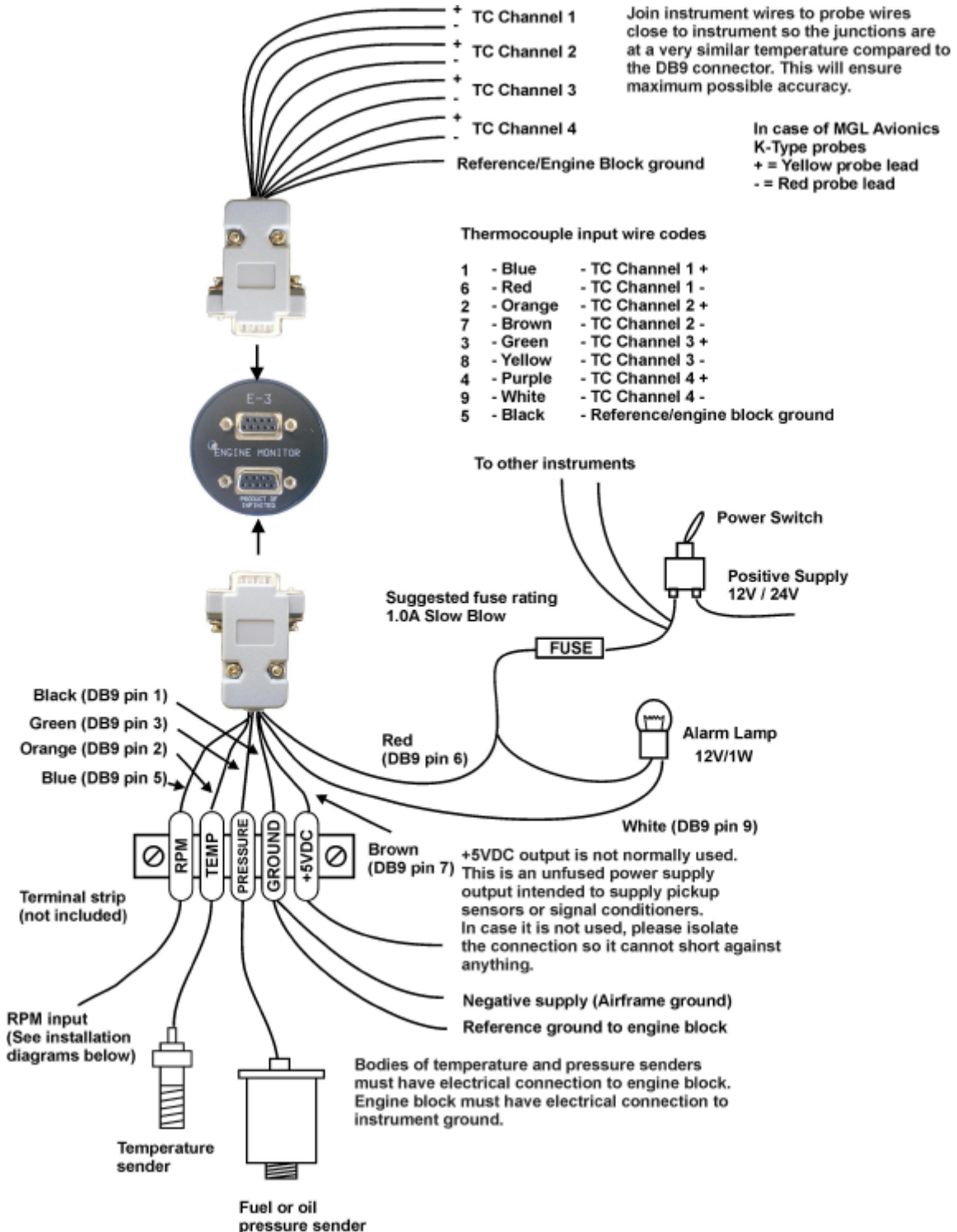

10.2 EGT/CHT Installation

The E-3 provides for up to 4 thermocouple inputs for use with EGT and CHT probes. K, J as well as E type probes can be used. K types are used for EGT probes while CHT probes can either be J or K type. -type probes are seldom used. Probe types are selected in the various "TC SETUP" menus of the E-3.

Important: Incorrect selection of probe type will lead to an incorrect temperature display.

The E-3 will accept both grounded and isolated thermocouple probes. Your only consideration in case of the more common grounded configurations is that you need to ensure that the thermocouple mounting position (exhaust flange, etc.) is at the same electrical potential as the negative supply line of the E-3.

The thermocouple amplifier is a precision device providing full cold junction compensation. In addition the amplifier measures and corrects for its own errors. This results in a very accurate measurement provided that you install high quality probes. Here are some guidelines:

EGT Probes: Select probes that are made from 316 stainless steel and that use glass-fiber insulated conductors. Teflon insulated conductors as found in many cheap probes introduce errors as the insulation melts moving the measuring point towards the mounting bolt which transfers a lot of heat to the exhaust material. This results in under reading probes. Stay away from probes that use simple plastic heat shrink sleeving – it does not last. Choose probes that use a generous amount of stainless steel spring as strain relief. The bolt itself should be stainless steel as well or it will rust very quickly.

CHT Probes: These are made from washers to fit spark-plug bases. Temperatures are considerably lower so most thermocouple cables will work without problems. The biggest area of concern should be the connection of the thermocouple cable to the washer. This often breaks after the spark plug has been changed a few times. Choose a probe that is suitably reinforced at this point for a long and trouble free life.

EGT and CHT probes supplied by MGL Avionics are of the highest quality. We recommend that you consider using our probes if at all possible.

Warning: Four stroke engines produce much hotter exhaust gases compared to two stroke engines. Do not use EGT probes made from lower grade stainless steel (for example 310), these probes will not withstand the high temperatures and can fail as the metal gets very soft at 800 degrees C. Many four strokes (such as the Rotax 912) will produce exhaust gases of up to 850 degrees C.

Important installation note:

EGT and CHT probes use wire made from iron and other basic metals. As a result these probes are not able to withstand much flexing of the wire due to engine vibration. Avoid making nice looking coils or similar constructions that will result in excessive vibration or flexing of the wire. Route the cables from the probe points tightly along suitable engine mounting points eliminating any chance of unnecessary wire flexing during engine operation.

10.3 Extending leads of thermocouple probes

Thermocouple leads as used with the EGT and CHT probes can be extended either with ordinary copper cable or with special K-Type extension cable. The choice of either depends on your desired accuracy. If it is possible in your installation to ensure that both ends of a copper extension cable will be at the same temperature (or very close), then it is quite possible to use the copper cable. In most open-air installations this will be the case. Should this not be possible or you require best possible accuracy at all times, you can obtain a special K-type extension cable. This cable is made from the same metals as your probes cable and uses ordinary plastic sleeving as insulation. In either case, ensure that the cable is not routed close to sources of electromagnetic interference of any kind. The voltages present in this cable are very small and are subject to changes applied by external fields. This can lead to false temperature indications. You can check your installation by using a hand-held transmitter, such as an air band radio. If you transmit a signal, no change in temperature reading should occur.

10.4 Temperature senders

Four types of senders can be fitted:

Water temperature senders (NTC types): A suitable sender with the same thread used by Rotax can be obtained from MGL Avionics (manufacturer Echlin).

Water/Oil temperature senders (NTC types): A standard 50°C to 150°C VDO automotive sender as fitted by Rotax to 912/914 engines can be used.

MGL Precision senders (National Semiconductors LM335): These are senders containing a semiconductor temperature measurement device. They can be used for water or oil temperature. These senders are available in two types: an encapsulated version with a brass housing suitable for Rotax thread; a second uncommitted version contains only the sensor itself. This can be conveniently mounted inside an existing sender housing after you remove the original insides of the sender. This is intended to give you a solution for unusual or difficult to obtain senders.

Most NTC senders require a single wire connected as shown. The sender is grounded via the engine block. The ground terminal of the gauge input should be connected to the engine block. Some NTC senders have two wires. In this case it is not required that the sender housing itself is connected to the engine block. Wire the second wire to the reference ground terminal.

User defined senders: The E-3 has a user sender calibration feature that can be customized for senders not listed above.

See the temperature setup menu for more details.

10.5 Pressure senders

Pressure senders come in two basic varieties. The first are the automotive types (e.g. VDO), the second are the electronic types with linear output. Most pressure senders used for engines are piezo-resistive types. These tend to have a very low resistance at low pressures and a high resistance at their maximum pressure output. The resistance is approximately linear with pressure. The E-3 supports both increased resistance with pressure as well as decrease resistance with pressure types. The E-3 allows you to choose the pressure sender type as described in the relevant section of this manual. Most automotive types have resistance ranges from 10 to 400 ohms. For example: the oil pressure sender as installed in a Rotax 912/914 engine has approx. 10 Ohms at 0 Bar and 180 Ohms at 10 bars.

Linear output senders that can be used with the E-3 are those types that have their maximum output voltage of 5V at their maximum pressure output.

Senders can have either one or two wires, the two wire senders need one connection to ground. Wire them up as indicated in the drawing. Please note that two wire senders may be sensitive to polarity. One of the two wires is a dedicated ground terminal that has to be connected to ground (minus of the battery or engine block).

The E-3 has a user sender calibration feature that can be customized for senders not listed above.

See the pressure setup menu for more details.

10.6 Senders that are grounded in the engine block

Most of the senders are “grounded configurations”. This means they connect electrically to the engine block. It is vital for good and stable readings that you connect the “Ground” terminal of the E-3 to the engine block using a short, good quality electrical connection. Never use sealant or PTFE tape on the threads of the senders. This may electrically isolate

the senders which will result in incorrect indications. The threads on these senders are expanding threads which are designed to create a tight metal to metal seal.

10.7 RPM Installation

After you have connected the rev counter terminal to the signal source you need to set the number of pulses per revolution under the “RPM SETUP” menu. The calibration itself depends on your engine type and what kind of signal you are using. Typical sources are:

- Magneto coils (suitable signal at the kill switch)
- Primary (low voltage) side of ignition coil, at contact breaker or electronic ignition module
- RPM counter output of electronic ignition systems (for example Bosch Motronic)
- RPM pickup devices such as hall-effect sensors on flywheels etc.

Please see the engine connection diagrams for the RPM connection to the E-3. The E-3 input is quite universally usable. The rev counter input on the E-3 can be used with signals from about 5Vpp to as much as 100Vpp and the input is AC coupled for easy installation. A noise filter is included that results in the input ignoring any noise signals as long as this is below the detection threshold of about 2.5Vpp. The input impedance of the rev counter input is approximately 10Kohm. You can use series resistors as well as load resistors for applications that have unusual signals.

For installations such as with the Rotax DCDI two-stroke engines, the rev counter input is simply connected to the grey rev counter wire from the engine. These engines produce six pulses per rev (set this up in the relevant menu item). Most engines produce 0.5, 1, 2 or 6 pulses per revolution. This needs to be setup in the “RPM SETUP” menu item.

Please note: The +5V supply line is unprotected and intended only for the supply of a hall-effect, optical or gear tooth sensors. Connecting any voltages (such as the 12V supply) to this line could destroy the instrument. The +5V line may supply currents of up to 30mA. Should your sensor require greater currents you must supply it from another source.

Please note: It is essential that a single wire be connected from the minus terminal of the instrument to the engine block. This wire must not be used to share currents with other electrical users as this can affect accuracy of readings.

10.8 Adjusting RPM sensitivity

The E-3 has a RPM sensitivity adjustment trimmer as shown in the picture below. Adjust this trimmer using a small screwdriver such that you get stable RPM readings over the entire rev band of your engine. If your sensitivity is too high, you may get unstable RPM readings (usually at higher RPM as electrical noise in the ignition system increases). If the sensitivity is too low the RPM reading may remain at zero.

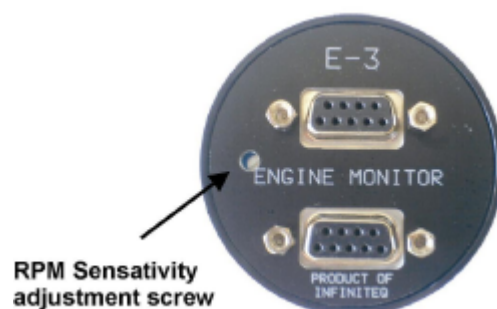

10.9 Connecting the E-3 RPM input to automotive engines

Conventional contact breaker ignition system

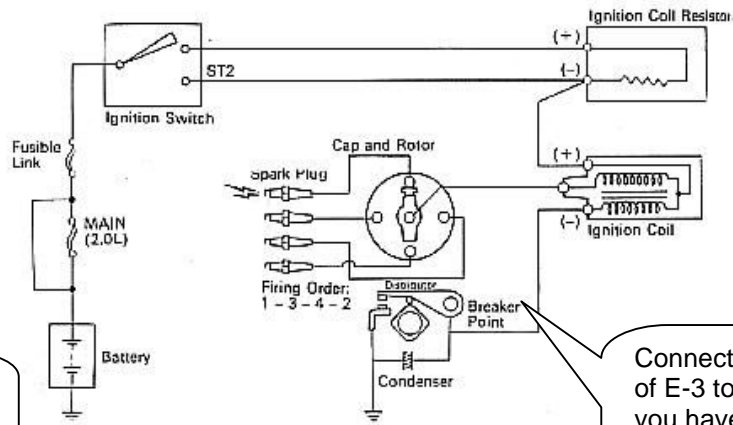

Use the tacho line if your system has such a signal

Connect rev counter input of E-3 to this line. Ensure you have a connection from the E-3 ground to the engine block.

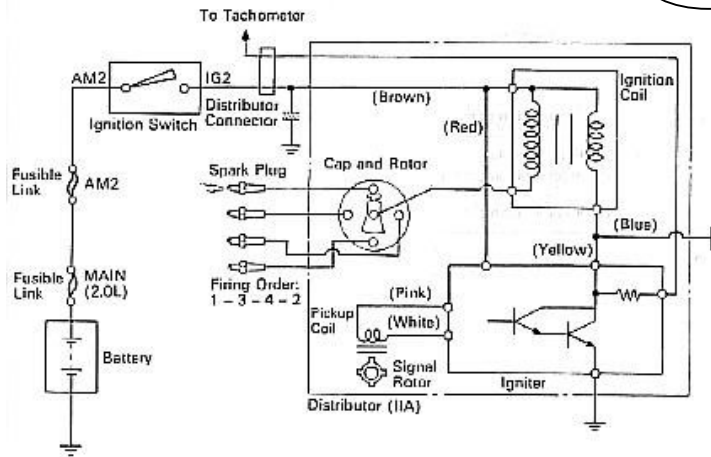

Connect rev counter input of E-3 to this line. Ensure you have a connection from the E-3 ground to the engine block.

Electronic ignition system with conventional ignition coil

10.10 Connecting a Bendix magneto as a RPM source

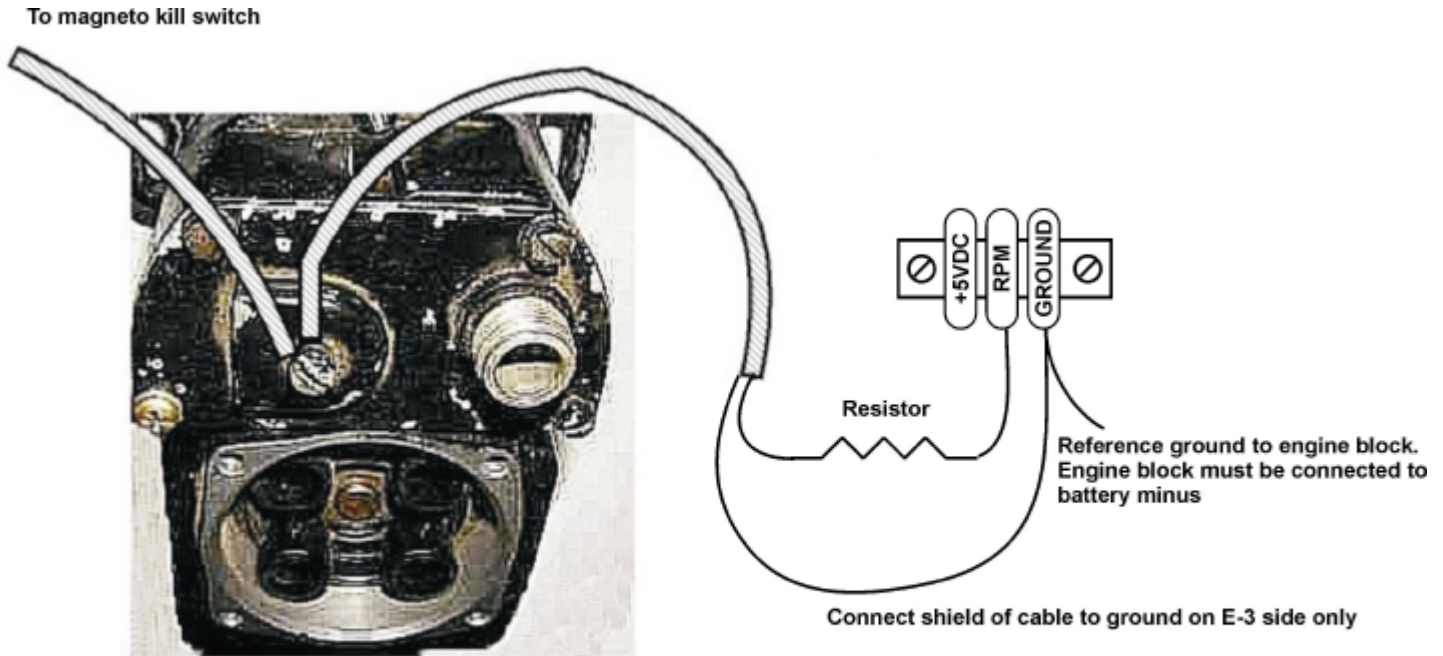

Typical connection to a Bendix P-Terminal.
This terminal will have a wire going to your
magneto kill switch or starter switch. Please
note that various kinds of terminals are used
on the many different types of Bendix magnetos

The above drawing shows the connection required if you would like to connect a magneto as RPM source. Shown is a typical Bendix magneto as used on Lycoming and other aircraft engines. You should find a wire connected to a terminal on the magneto that originates from your magneto kill switch (or starter switch). The terminal is often referred to as a "P-terminal". Connect a wire as shown and connect this to the RPM input of the E-3. We strongly recommend that a resistor is inserted into your wire as shown. A good value would be 10,000 ohms (10K). A normal 1/4 W resistor is just fine. The above circuit can also be used on other magneto systems such as found on Jabiru and similar engines.

The supplied 220 Ohm ballast resistor should not be used on the above installation.

10.11 Various other pickup/sensor installation possibilities

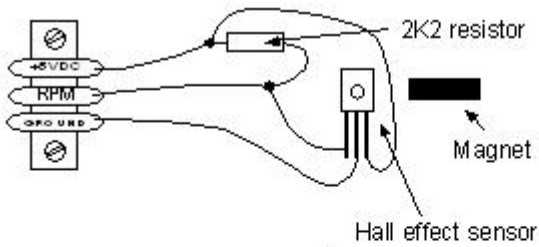

Typical hall effect sensor installation detects the passing of a magnet suitably fixed to prop flanges or shafts.

Magnetic pickup with Hall effect sensor

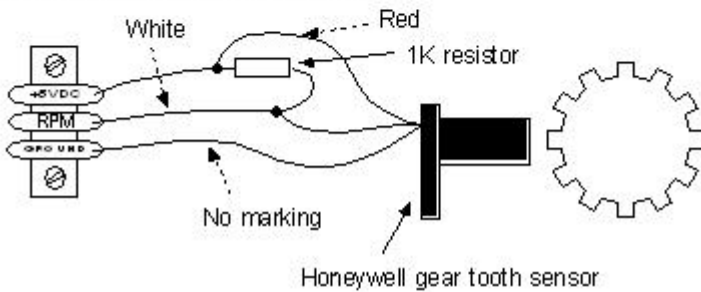

The gear tooth sensor is a popular pickup used on the pre-rotation gear of a gyro plane (rotor speed indication).

Magnetic pickup with active gear tooth sensor

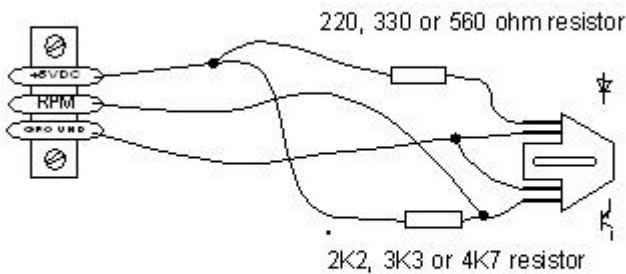

Optical, reflective sensor

The optical reflective pickup can provide a simple means of contactless RPM sensing in difficult installations.

10.12 Connection diagram for a Rotax 503 or 582 engine

This diagram shows EGT, CHT and water temperature sender locations and wiring based on a Rotax 582. This is a water cooled engine so CHT senders should be viewed as optional. For a Rotax 503 or similar air-cooled installation, proceed similar but omit the water temperature sender and wiring.

Ground wire connects to a suitable ground point on engine block.
Note: Engine block needs to be electrically connected to negative terminal of aircraft battery.

Join instrument wires to probe wires close to instrument so the junctions are at a very similar temperature compared to the DB9 connector. This will ensure maximum possible accuracy.

In case of MGL Avionics K-Type probes
 + = Yellow probe lead
 - = Red probe lead

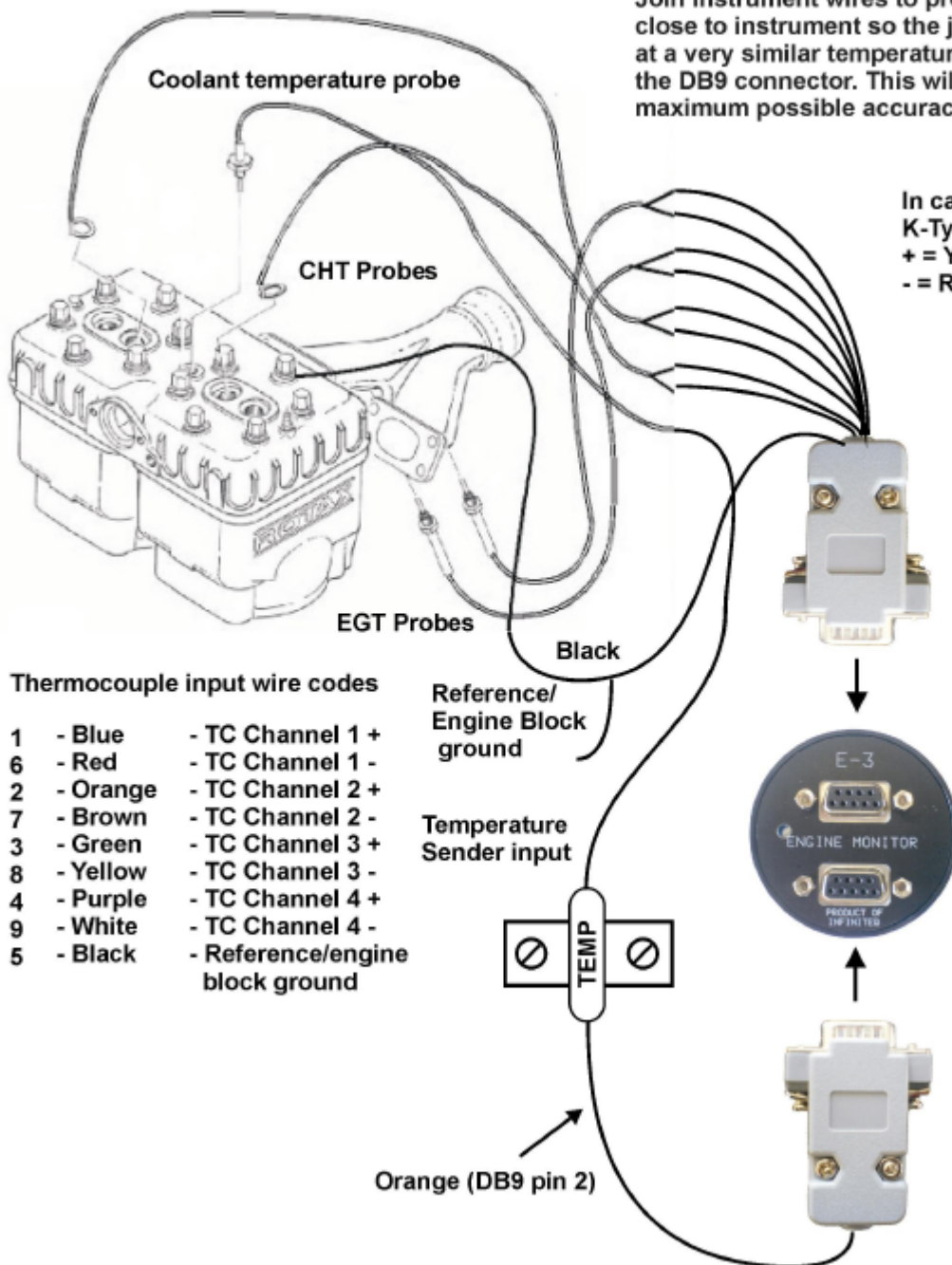

Other wiring not shown, please refer to the general connection diagram

Please note that the ground connection (black wire) from the E-3 must be connected to the engine block as shown. Select a suitable point on your engine block for this connection. The engine block itself needs to be connected to the negative supply, in all cases this should be a direct connection to your batteries minus terminal. This should be a thick copper cable with a very low resistance and it needs to be as short as possible. This requirement is even more severe if you are using electric start as the very considerable currents required by the starter motor will be using this connection.

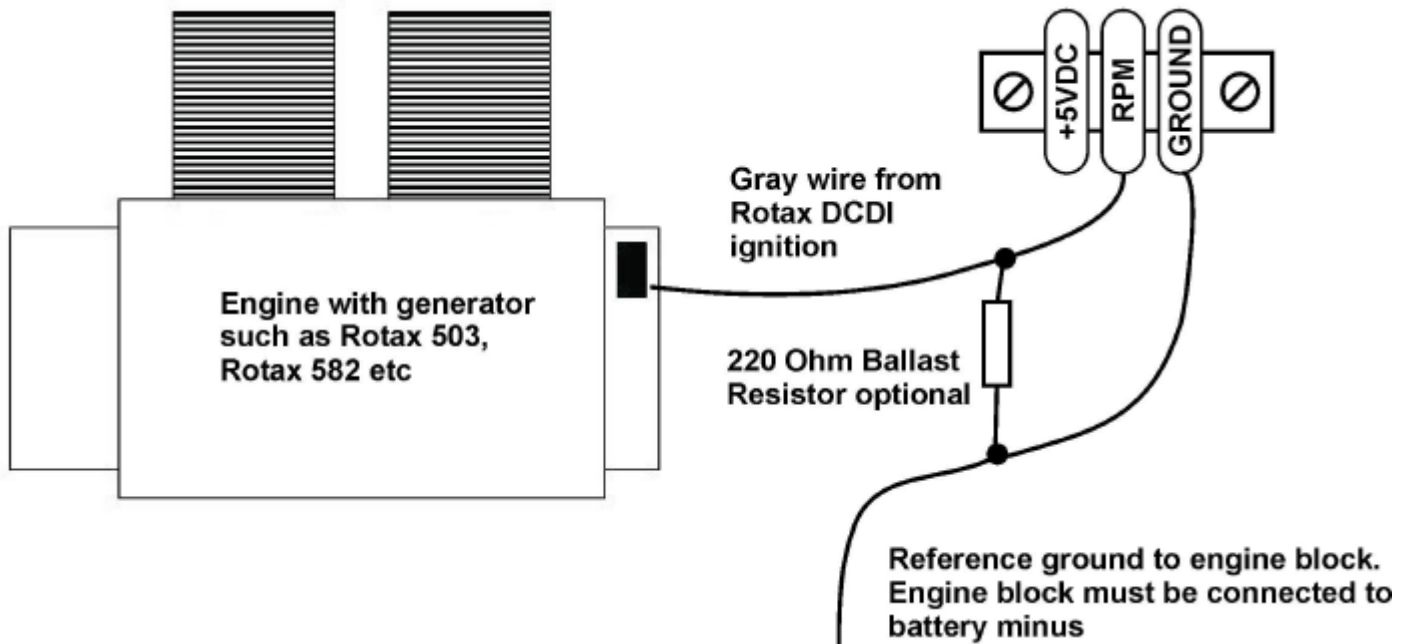

For this engine we recommend that you use the supplied 220 ohm ballast resistor. Select a value of 6.0 for pulses per revolution under the "RPM SETUP" menu.

Note: Some Rotax engines may require that a 220 ohm ballast resistor is fitted between the rev counter input and the ground terminal. This resistor should be fitted if you cannot obtain stable RPM throughout the range regardless of any setting of the rev counter sensitivity adjustment.

10.13 Connection diagram for a Rotax 912 or 914 engine

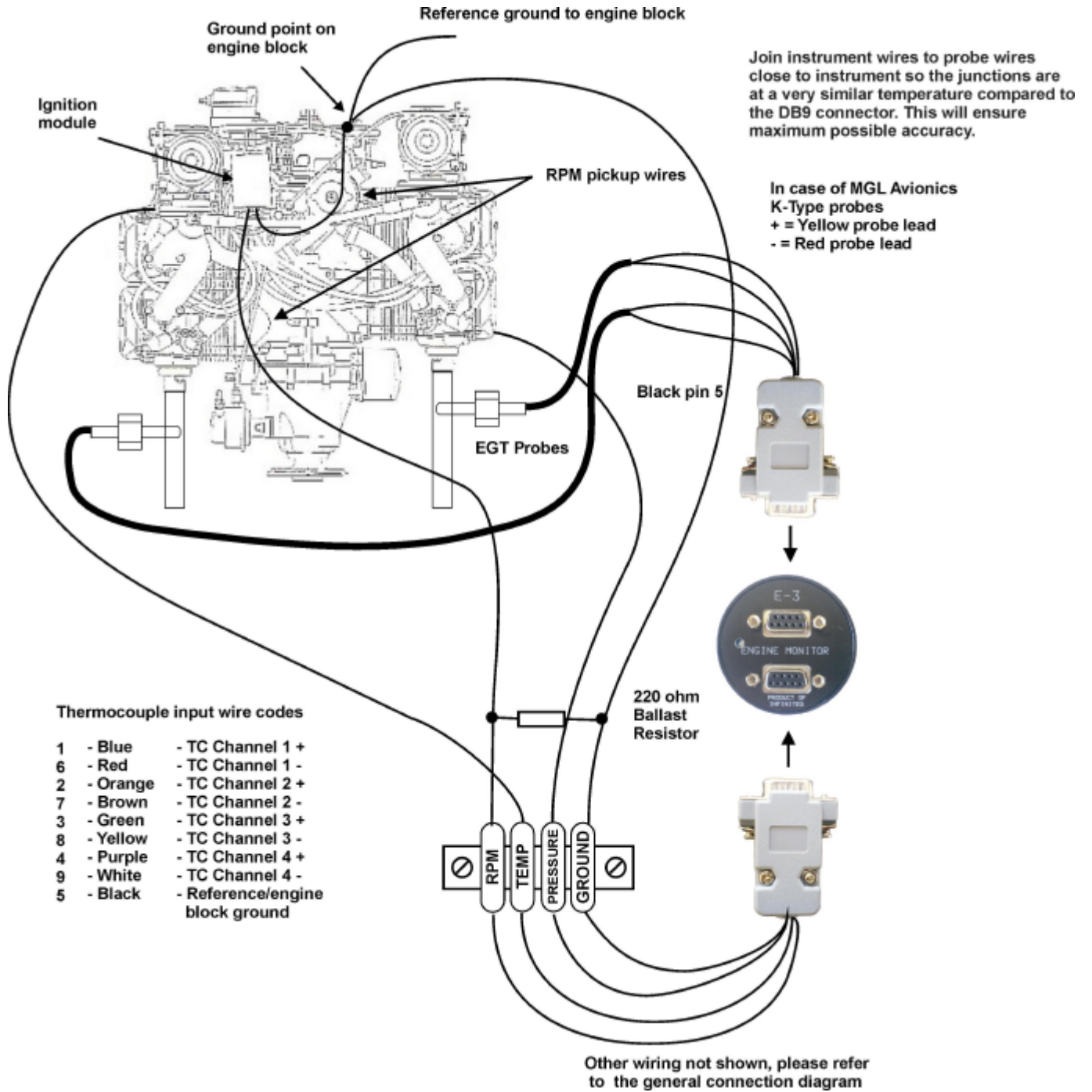

This installation assumes that two EGT are used (you can install up to four EGT, one for each cylinder). This installation makes use of the two built in NTC type cylinder head temperature senders.

Connect the rev counter wires (blue/yellow and white/yellow) as follows: One of the two wires needs to be connected to ground (engine block), the other to the RPM counter input. For this engine we recommend that you use the supplied 220 ohm ballast resistor. Select a value of 1.0 for pulses per revolution under the "RPM SETUP" menu.

10.14 E-3 DB9 Cable connections

Main Connector (Bottom DB9 Connector)

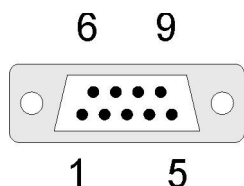

DB 9 Pin	Color	Function
1	Black	Ground
2	Orange	Temperature Sender input
3	Green	Pressure Sender input
4	NC	Airtalk communication (Not connected) Used for firmware upgrading
5	Blue	RPM Input
6	Red	8-30Vdc power
7	Brown	+5VDC Power Out
9	White	Alarm Output

Thermocouple (EGT/CHT) input connector (Top DB9 connector)

In case of MGL Avionics K-Type probes + = Yellow probe lead, - = Red probe lead

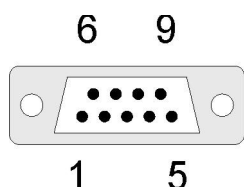

DB 9 Pin	Color	Function
1	Blue	TC Channel 1 +
2	Orange	TC Channel 2 +
3	Green	TC Channel 3 +
4	Purple	TC Channel 4 +
5	Black	Reference ground (connect to engine block)
6	Red	TC Channel 1 -
7	Brown	TC Channel 2 -
8	Yellow	TC Channel 3 -
9	White	TC Channel 4 -

11 Warranty

This product carries a warranty for a period of one year from date of purchase against faulty workmanship or defective materials, provided there is no evidence that the unit has been mishandled or misused. Warranty is limited to the replacement of faulty components and includes the cost of labour. Shipping costs are for the account of the purchaser.

Note: Product warranty excludes damages caused by unprotected, unsuitable or incorrectly wired electrical supplies and/or sensors, and damage caused by inductive loads.

12 Disclaimer

Operation of this instrument is the sole responsibility of the purchaser of the unit. The user must make themselves familiar with the operation of this instrument and the effect of any possible failure or malfunction.

This instrument is not certified by the FAA. Fitting of this instrument to certified aircraft is subject to the rules and conditions pertaining to such in your country. Please check with your local aviation authorities if in doubt. This instrument is intended for ultralight, microlight, homebuilt and experimental aircraft. Operation of this instrument is the sole responsibility of the pilot in command (PIC) of the aircraft. This person must be proficient and carry a valid and relevant pilot's license. This person has to make themselves familiar with the operation of this instrument and the effect of any possible failure or malfunction. Under no circumstances does the manufacturer condone usage of this instrument for IFR flights.

The manufacturer reserves the right to alter any specification without notice.

Other instruments in the Stratomaster Infinity series

ALT-1	Precision encoding altimeter and vertical speed indicator
ALT-2	Precision encoding altimeter and vertical speed indicator with a serial RS232 transponder output
ASI-1	Airspeed indicator (ASI) with automatic flight log
ASX-1	Encoding aviation altimeter with serial output and airspeed indicator (ASI)
AV-1	Artificial horizon and magnetic compass indicator
BAT-1	Battery voltage and current monitor
E-3	Universal engine monitor
FF-1	Fuel computer (single or dual fuel tanks)
GF-1	+/-10G tilt compensated dual range G-force meter
MAP-1	Universal pressure indicator
RV-1	Universal engine RPM and rotor RPM Indicator
RV-2	Universal turbine RPM / RPM factor display
RTC-2	Aviation real time clock (RTC) and outside air temperature (OAT) display
TC-1	4-Channel thermocouple indicator
TP-1	Universal temperature and pressure gauge